



CONFEDERATION OF AUTOSPORT CAR CLUBS

General Competition Regulations

Effective January 1, 2023

Revised January 1, 2023

No express or implied warranties of safety or fitness for a particular purpose shall be intended or result from the publication or compliance with these or any other official regulations.

All rights reserved. This book may not be reproduced in any form or by any means without written permission from the Confederation of Autosport Car Clubs.

Confederation of Autosport Car Clubs
18978 119 Ave
Pitt Meadows, BC V3Y 1X6

www.caccautosport.org



Table of Contents

1	Terminology	3
2	General.....	7
3	Participants.....	10
4	Competitors and Drivers	11
5	Organization of Events.....	13
6	Event Regulations	17
7	Conduct of Events.....	20
8	Stewards	21
9	Officials and their Functions.....	24
10	Flag Signals	29
11	Penalties.....	31
12	Inquires.....	36
13	Protests	37
14	Appeals	43
15	Insurance Requirements	46
16	Roll Cage Specifications	47
17	Roll Bar Specifications	52
18	Competitor Safety Equipment	55
19	Driver Restraint System	57
20	Vehicle Safety Requirements.....	60
21	Racing Numbers and Class Designation	64
22	EV (Electric Vehicle) Electrical Safety	65

1 Terminology

The following definitions shall apply to this Rulebook regardless of any other definitions or interpretations.

ASN	A national sporting authority for a country, appointed by the FIA.
AUTOMOBILE	A land vehicle propelled by its own means, running on at least four wheels not in a line, which must always be in contact with the ground and of which at least two must affect steering and at least two the propulsion.
AUTOCROSS	An event generally held in fields, on soft or hilly ground, or an abandoned gravel quarry. The terrain itself requires car handling skill on the part of the competitor.
AUTOSLALOM	An Autoslalom is a non-speed driving skill contest such as, but not limited to, autocrosses and slaloms. They are run on short courses that emphasize the driver's ability and the cars handling and agility. Racing licenses are not required, and hazards to spectators, participants and property do not exceed those encountered in normal, legal highway driving. The course will not require the driver to stop and/or reverse between the start and finish box of a given run.
CACC or CONFEDERATION OF AUTOSPORT CAR CLUBS	Confederation of Autosport Car Clubs is the designated sporting authority for automotive competitions in the province of British Columbia. Its duties and powers include, but are not limited to, assuring that automotive competitions are conducted in accordance with the provisions set out in this Rulebook. It shall be referred to hereinafter as CACC.
CACC EXECUTIVE	The CACC Executive is the group of four or more individuals responsible for the administration and overseeing of the conduct of events, and the enacting of policies as adopted by the membership of the CACC.
CACC AFFILIATE	Any motor sport club or corporation in British Columbia that is affiliated with the Confederation of Autosport Car Clubs.
CLASS	A group of Cars, classified according to the provisions of the Regulations.
CLUB EVENT	A competition confined solely to the members of the club organizing the competition and invited competitors.
CLUB	Any Body recognized by CACC as a club.
COMPETITION	A contest in which an automobile takes part, and which is of a competitive nature or is given a competitive nature by publication of results. A sanctioned competition is an event held under the General Competition Rules (GCR) of CACC as well as the applicable CACC regulations with an appropriate permit applied for from the CACC Executive.

COMPETITOR	A person whose entry is accepted for any event or who competes in any event, whether as an entrant or as a driver.
CONTROL LINE	The line by reference to which an automobile is timed or its performance in a competition is determined.
COURSE	The route to be followed by a competitor in a competition.
DISCIPLINE	All CACC competitions are categorized by type of activity or "discipline" (e.g., Race, Ice Race, Slalom etc.)
DRIVER	A person nominated as the driver of an automobile in any competition.
ENTRANT	A person or organization whose entry is accepted for any competition.
EVENT	An entire program of Competitions. An Event is deemed to begin when Competitions begin and to end when all Competitions are concluded.
EVENT SUPPLEMENTARY REGULATIONS	Regulations that are presented by the organizer of an event.
EVIDENCE	That which supports fact, logic or reason.
FACT	Something that can be proven.
FIA	Fédération Internationale de l'automobile, the International Federation of National Automobile Clubs.
FINISHING LINE	The last control line on a marked race track. The finish line may also be the starting line. The timing control line may be an unmarked different line.
FORCE MAJEURE	A situation whereby it is unreasonable to start or continue a competition or to fully apply a regulation (an act of God).
GENDER INTERPRETATION	In this Rulebook, any reference to the masculine shall include the feminine, and references to the singular shall include the plural.
ICE-X	Generally, an Autocross event similar to a slalom, though held on snow or ice.
ICSCC	The International Conference of Sports Car Clubs.
KART	A land single seater vehicle without a roof or a cockpit, without suspension and with or without body work, with 4 non-aligned wheels that are in contact with the ground, the 2 front ones which control the direction, and the other 2 rear ones, connected by a one-piece axle, transmit the power. The main parts are the chassis (including the bodywork), the tires and the engine.
LICENCE	A certificate of registration issued by CACC or an ASN to any person wishing to take part in competitions.

LICENSED COMPETITOR	A Licensed Competitor is a competitor who has applied for and received a CACC Competition Licence that is valid for the current competition year.
MARKED RACETRACK	That portion of a race track that is used by cars for racing and includes the paved surface, any curbing that exists and the pit lane. On some tracks the primary racing surface is indicated by painted lines.
NON-SPEED EVENT	An event in which speed is not the total determining factor, although timing of the vehicles is usually considered as in a slalom, autocross, drifting, etc.
OPEN EVENT	A competition in which participants comprise of members of any recognized CACC member club.
ORGANIZER(S)	A person or persons approved by CACC and authorized by promoters, clubs, or other groups to organize an event on their behalf. Where an organizer is appointed to act on behalf of promoters, such organizer shall take the place of such promoters for the purposes of these GCRs and shall be deemed to be the agent of the promoters.
ORGANIZING PERMIT	The documentary authority to organize and hold a competition granted solely by CACC.
PARTICIPANT	Any person or body involved at an event as an official, entrant, driver, crew or worker.
PENALTY	A punishment for breaching a rule or regulation.
PRIMARY SPONSOR	A Primary Sponsor is a sponsor who has contracted with the CACC to act as the main sponsor of the Event held on a given site on a given day. In doing so, this sponsor will be granted an uncontested sponsorship presence. Other sponsors and their vehicles are welcome on the event site but are prohibited from erecting any static displays or banners. Additionally, these other sponsors will be required to locate their pit areas in low profile areas within the site.
PROGRAM	A document prepared by the promoters and/or organizers of an event for the purpose of informing the participants and spectators about such a meeting.
PROMOTER	Any person or body (other than an organizer) proposing to hold, or holding a series, event or competition.
RACE	An individual competition that is a part of a race meet (or Event).
RACE MEET	A number of individual competitions.
RACETRACK	The entire property upon which a marked racetrack is situated.
RACETRACK LICENCE	The licence for a racetrack issued by CACC, an ASN and in some cases FIA.
RESTRICTED COMPETITION	An event which is restricted as defined in supplemental regulations.



SANCTIONED EVENT	Any event or competition authorized and approved by CACC and having the appropriate organizing permit.
SCCA	The Sports Car Club of America.
SEASON	One calendar year.
SLALOM	Alternate terminology for an Autoslalom.
SOLO EVENT	Solo Event is any event (where an event is considered to be an entire program of competitions) in which one automobile at a time is timed over a clearly defined course, with elapsed time and appropriate penalties for course deviations being the determining factor for awards. This shall not preclude the running of more than one car at a time, provided they are separated on course by adequate time and distance to eliminate any possibility of a passing situation.
SPEED EVENT	An event in which vehicles run individually (even though two or more may be in motion simultaneously) and in which the relative performance of the competitors is assessed by timing them over a given distance.
STARTING LINE	The control line on a marked event course and represents the point at which an event first commences. This line may also be the finishing line. The timing control line may be an unmarked different line.
SUPPLEMENTARY REGULATIONS	Regulations drawn up by the organizers of a competition or competitions and approved by CACC with the object of laying down details of such competitions. These are supplementary to these GCRs and the regulations of CACC.
TIME ATTACK	A competition conducted at permanent motorsport facilities or other facilities suitable for racing where passing is allowed in designated passing zones and run sessions based on time are used to determine a competitor's fastest lap time. May be designated as a "With Passing" or "Without Passing" event.
VEXATIOUS	Of little or no significance or importance, annoying or disturbing.

2 General

2.1 Regulatory Authority

- 2.1.1 These regulations are issued pursuant to the authority assumed by the Confederation of Autosport Car Clubs (CACC).
- 2.1.2 CACC has drawn up these regulations referred to herein as "these regulations". These regulations are effective as of January 1, 2021 and as amended from time to time.
- 2.1.3 CACC is the sole regulatory authority and shall render all decisions concerning these regulations; determine eligibility for participation in competitions; appoint officials; issue and withdraw licenses; apply penalties for violation of these regulations; carry out all actions deemed in its judgment to be in the best interests of the conduct of motorsport.

2.2 Organization of CACC Events

- 2.2.1 A CACC sanctioned event may be organized by:
 - 2.2.1.1 CACC
 - 2.2.1.2 A CACC affiliated club

2.3 CACC Competition Regulations

- 2.3.1 The headings used in these regulations are not to be read into the regulations.
- 2.3.2 CACC reserves the right to alter these regulations at any time.
- 2.3.3 CACC bulletins become part of these regulations.
- 2.3.4 Each organizer drafts event supplementary regulations, which are submitted to the appropriate CACC Discipline Director for approval.
- 2.3.5 These regulations have been prepared in English text, which shall prevail in terms of meaning and intent.

2.4 Knowledge of Regulations

- 2.4.1 Every person, body, group of persons, etc., promoting a series; organizing a competition or event or taking part therein; or by and upon applying for an agreement, sanction or permit or licence of any kind from CACC; by and upon participation at a competition as an entrant, driver or otherwise shall by doing so be deemed to and recognize that:
 - 2.4.1.1 They have acquainted themselves with these regulations.
 - 2.4.1.2 They have submitted themselves without reservation to the consequences resulting from the application of these regulations.
 - 2.4.1.3 Have renounced, under pain of disqualification, the right to have recourse to any arbitrator or judicial tribunal not provided for in these regulations.

- 2.4.1.4 Have agreed to exonerate and keep indemnified all bodies; sponsors and their agents, race track owners, race owners, race organizers and their officials and agents, CACC and its directors, officers, officials and its subsidiaries, agents and associate members, from and against all liability whatsoever to any such person or body or group of persons respectively in respect of, or in connection with any meeting, competition, or event held under these regulations, from whatever cause arising or alleged to arise and notwithstanding that the same may have been contributed to, or occasioned by, the negligence of the said bodies, their agents, officials, servants, or representatives.
- 2.4.1.5 In the case of entrants for, and drivers in, events, have agreed in the circumstances aforesaid in 2.4.1.4 to exonerate and keep indemnified all and any other competitors, their servants and agents, from and against any liability whatsoever, including direct liability, to such entrants or drivers in connection with the driving of cars or any other act, omission, or occurrence during the course of a competition or official practice.
- 2.4.1.6 Have agreed as set out in regulations 2.4.1.4 and 2.4.1.5 of this regulation with each and all the persons and bodies referred to in those regulations and so that each any of these persons or bodies shall be entitled to the benefit of such agreements.
- 2.4.2 Every driver, entrant, official, promoter or other participant in a CACC sanctioned event, and every person who is issued a CACC licence agrees without reservation to conduct themselves in accordance with these regulations. If there is a disagreement or dispute regarding the meaning or application of these regulations, the interpretation and application by CACC officials at the track shall prevail. In order to promote the sport of auto racing, to achieve prompt finality in competition results, and in consideration of receiving numerous benefits available to them, all CACC members and licence holders expressly agree that determinations by CACC officials as to the applicability and interpretation of this code are non-litigable, and they covenant that they will not initiate or maintain litigation of any kind against CACC or anyone acting on behalf of CACC, to reverse, modify or obtain relief from such determination for no purpose other than a bad faith intent to harm the member or licence holder. If a member or licence holder initiates or maintains litigation in violation of this covenant, that member or licence holder agrees to reimburse CACC for the costs of such litigation, including legal fees.

2.5 Precedence of Regulations

- 2.5.1 The precedence of regulations shall be as follows:
- 2.5.1.1 These CACC regulations
 - 2.5.1.2 CACC competition regulations issued by the individual CACC discipline committees
 - 2.5.1.3 CACC bulletins
 - 2.5.1.4 Series regulations
 - 2.5.1.5 Event supplementary regulations
 - 2.5.1.6 Instructions from CACC officials

2.6 Licensing of Event Officials

- 2.6.1 Certain officials at a sanctioned event may, as a condition of the event permit, be required to be licensed as follows: Steward, Clerk of the Course, Kart Race Director, Deputy Clerk of the Course, Chief of Timing & Scoring, Starter, Chief Scrutineer, Chief Course Marshal, Chief Communicator, Chief Registrar and Pace Car Driver.

2.7 Authority of CACC Officials

- 2.7.1 Only CACC appoints stewards and other officials as necessary.
- 2.7.2 CACC stewards have complete authority for the enforcement of all applicable regulations as stipulated in Section 2.5.1.

2.8 Calendar of Competitions

- 2.8.1 CACC shall publish an annual calendar of competitions.

2.9 Publications

- 2.9.1 Publications made by promoters, sponsors and organizers, in connection with or resulting from CACC competitions shall be produced in accordance with the laws of the land, be in good taste and shall not be misleading or untruthful.
- 2.9.2 Publications, under these regulations, means; radio and television productions and promotional videos; printed advertisements, online content, brochures, booklets, forms, signs or displays.
- 2.9.3 Publications shall include the logo of CACC and the wording "Sanctioned by CACC".

3 Participants

3.1 Conduct of Participants

- 3.1.1 Participants in a CACC sanctioned competition shall conduct themselves according to the highest standards of behaviour and sportsmanship, particularly in relations with other competitors, officials, sponsors, and their products, and in a manner that shall not be prejudicial to the reputation of CACC, promoters, sponsors, organizers, or to motorsport in general. Failure to do so may result in penalties.
- 3.1.2 Entrants and drivers are at all times responsible for the conduct of their crewmembers and guests. A violation of these regulations committed by an entrant, driver, crewmember or guest may be directly chargeable to the driver and result in penalties that may ultimately affect the outcome of a competition.

3.2 Alcoholic Beverages and Cannabis

- 3.2.1 Participants at an event shall not consume alcoholic beverages or any form of cannabis during the event. The steward may prohibit participation if it is suspected that any such substances have been consumed. Any action taken, or penalty applied by the steward in this regard is not subject to protest or appeal.

3.3 Narcotics and Drugs

- 3.3.1 The use of any narcotic or illegal substances, as defined in law, or the improper use of legal substances, by any participant is prohibited. The steward may prohibit participation if it is suspected that any such substances have been consumed. Such action is not subject to protest or appeal.
- 3.3.2 Any consumption of prescription medication taken while under the care of a physician or over the counter remedies should be reported to the event medical personnel by the participant.
- 3.3.3 Pharmaceutical drugs that may sufficiently affect normal alertness are also included in this Policy.

3.4 Submission to Testing

- 3.4.1 CACC reserves the right to require any participant to submit to and complete; breath, blood, urine, or other tests designed to determine the presence of alcohol, narcotics, dangerous drugs, illegal substances or the inappropriate use of legal substances. Such action is not subject to protest or appeal.

4 Competitors and Drivers

4.1 Licensing of Competitors and Drivers

- 4.1.1 **Grant of Licence** – Application for and the granting of a licence shall be governed by the conditions laid down by CACC. The holding of a licence by an individual is a privilege and not a right. A licence issued by CACC may, for sufficient cause, be withdrawn or suspended at any time.
- 4.1.2 Every person who makes an entry for or who competes in an event held under CACC regulations shall be in possession of a current, valid competition licence of the grade required for that type of event. The discipline committee may authorize specific events or types of events for which a competition licence is not required.
- 4.1.3 **Licence Fees** – For a licence to be granted by CACC, a fee shall be payable to CACC in accordance with a scale laid down from time to time.
- 4.1.4 **Licensing** – For those events where licensing is required, the CACC licensing system is as follows:
- 4.1.4.1 Basic competition licence for each discipline
 - 4.1.4.2 Any other recognized CACC or affiliated ASN territory race licence

4.2 Refusal of Licence

- 4.2.1 CACC may refuse to issue a licence and state the reason for such refusal.

4.3 Period of Validity of Licence

- 4.3.1 Licences shall be valid from the date of issue to the end of the current calendar year, or such other date(s) CACC may specify.

4.4 Validity of Licence

- 4.4.1 A licence granted by CACC does not constitute a certificate of competency of the holder. No driver, who is suffering from any disability, permanent, temporary, or otherwise, which prejudicially affects the normal control of their faculties, shall compete in any event. Provided that where a driver is suffering from a permanent disability, the nature of which they have declared to CACC who have nevertheless issued a licence, such disability shall not debar the driver from competing in an event in compliance with any conditions endorsed on his licence.
- 4.4.2 If the holder of a licence granted by CACC is, during the currency of such licence, disqualified from holding a licence to drive automobiles on the highways in any province or territory of Canada, then their licence granted under these GCRs may become null and void and shall forthwith be returned to CACC. The CACC Executive Steward may, upon application by the licensee, consider the circumstances under which the disqualification was ordered and, if thought fit, authorize the re-issuance of such competitor's licence.
- 4.4.3 Canadians must hold a licence issued by CACC or an affiliated ASN territory. Canadians may only hold licenses issued by sporting authorities of other countries after receiving written authorization to do so from CACC.

4.5 Production of Licence

4.5.1 A competitor at an event shall produce their licence on demand to an official of that event.

4.6 Medical Responsibility of Driver

4.6.1 Any licence holder who suffers injury or illness that affects his medical fitness to participate in events shall report their injury or illness immediately to the event physician (if any) or CACC medical advisor and be re-certified by them or a physician they designate before competing in further CACC events.

4.7 Assumed Name

4.7.1 If a licence is required in an assumed name, special application therefore shall be made to CACC, which may, if it thinks fit, issue a license in such name. A person granted a licence in an assumed name shall, so long as they hold a licence in that name, not take part in any competition except under the name shown on the licence.

4.8 Change of Driver or Automobile

4.8.1 In a competition, change of driver or automobile shall be made only with the consent of the steward.

4.9 Driver Review

4.9.1 The CACC Executive Steward is authorized to convene a court to review a driver's conduct, car legality, competition record, and/or other matters. Such a court shall have the power to invoke penalties as specified in these GCRs and may revoke licenses. The driver shall have the right to appeal this court decision as specified in these GCRs.

5 Organization of Events

5.1 Application for an Organizing Permit

- 5.1.1 To conduct an event, an application for a permit to hold an event must be made to CACC. All permit applications will be received at the CACC office or an identified person no later than thirty (30) days prior to any event. Late applications will be subject to penalties as laid out in this rulebook.
- 5.1.2 An event shall not be held until CACC has granted an organizing permit and has received payment. CACC may attach conditions to the granting of a permit, decline to grant a permit or withdraw a permit and state a reason for so doing.
- 5.1.3 An application from an organizer, which has failed to discharge any requirements or any indebtedness to CACC in respect of previous events, will not be approved.
- 5.1.4 Application for a permit to organize competitions that are part of a CACC competition is restricted to CACC member clubs.

5.2 Conditions of Application

5.2.1 Event Documentation

All of the following is required in the hands of the CACC Executive 30 days prior to the event to avoid the penalties indicated below.

- 5.2.1.1 Copy of event permit.
- 5.2.1.2 Copy of insurance certificate.
- 5.2.1.3 Approved Supplementary Regulations.
- 5.2.1.4 A course map demonstrating pit area flow patterns, course worker locations, chief course marshal station, timing and P.A. area, tech area and registration area, where applicable.
- 5.2.1.5 Details of the following five items must be displayed at the event scoring or registration area:
 - 5.2.1.5.1 A complete event schedule (timetable) c/w tech and registration, walk throughs, pre-grid and lunch breaks, etc., openings and closings
 - 5.2.1.5.2 Permit
 - 5.2.1.5.3 Insurance
 - 5.2.1.5.4 Supplementary Regulations
 - 5.2.1.5.5 Course map
- 5.2.1.6 Each application will consist of the event permit application form, completed in full; event supplementary regulations including a schedule of events and entry fees; an event safety plan; an event entry form and the appropriate event sanction fee. Incomplete applications will be returned to the applicant and considered as not received.

- 5.2.1.7 Event organizers are responsible for drawing up and publishing event supplementary regulations that need not repeat these regulations or those of a series being run, however, under no circumstances may they conflict with these regulations or those of a series.
- 5.2.1.8 For all events, the event safety plan will include:
 - 5.2.1.8.1 A list of key personnel designated to respond to an emergency
 - 5.2.1.8.2 An equipment list for each control station
 - 5.2.1.8.3 Description of medical staff
 - 5.2.1.8.4 Emergency service vehicles
 - 5.2.1.8.5 Mobile firefighting equipment
 - 5.2.1.8.6 Provisions for spectator first aid
 - 5.2.1.8.7 Name(s) of hospital(s) to be used
 - 5.2.1.8.8 A brief description of the method to be used to summon outside assistance in the event of an emergency
 - 5.2.1.8.9 A detailed map showing routes to and from the event which are expected to be used by emergency vehicles
- 5.2.1.9 For race and other speed events the event safety plan will also include:
 - 5.2.1.9.1 Name of doctor(s) or medical officer
 - 5.2.1.9.2 Ambulance provisions
 - 5.2.1.9.3 Driver rescue/extrication equipment
- 5.2.1.10 The event safety plan should be available for inspection at the event by the Steward, and its location may be announced at the drivers' meeting.
- 5.2.1.11 Event permit applications can be made for an entire season at one time if so desired. These advance event permit applications must be accompanied by post-dated cheques to cover the applicable event permit fees for each event. These cheques will be dated no later than thirty (30) days prior to the event for which they apply.
- 5.2.1.12 Upon event permit application approval, an event permit will be issued to the applicant and a steward, if applicable, will be appointed by CACC. Once an event permit is issued there will be no changes allowed to any portion of the approved regulations without the written approval of the steward. Any unauthorized changes will be disallowed and may result in the withdrawal of the event permit and/or a fine as prescribed in the CACC GCRs.
- 5.2.1.13 This space intentionally left blank.
- 5.2.1.14 Each event permit will reference the track inspection certificate that has been issued for the venue at which the event will be held, and the applicant will be expected to adhere to any conditions attached to the issuance of that track inspection certificate. CACC will make full details of any track inspection available to the permit applicant.

- 5.2.1.15 If any of the conditions attached to the track inspection certificate are not met, fines may be imposed, or the event may be cancelled by the steward.
- 5.2.1.16 The applicant will supply a complete and detailed entry list to the steward prior to the start of the event with a final update no later than thirty (30) minutes after the closing of registration.
- 5.2.1.17 The applicant will supply a complete set of event results to CACC and to event competitors within seven (7) days of the completion of the event. Failure to comply will result in penalties as described in Section 11 of this rulebook.

5.2.2 Unrestricted Entry

A CACC championship event shall not be limited to members of any specific club.

5.2.3 Classification of Entries

A CACC sanctioned event may be classed under any system at the organizer's discretion. However, the organizers shall provide results conforming to the applicable CACC vehicle classification system.

5.2.4 Adverse Weather Conditions

A CACC sanctioned event shall proceed without consideration of weather conditions on the day of the event unless such conditions are severe enough so as to make it unsafe to conduct the event and warrant special consideration by the Organizer and the event Steward. Such conditions may include, but are not limited to, flooding, earthquakes, etc.

5.2.5 Rescheduling

In the event that a condition in 5.2.4 occurs, the organizer shall make arrangements to reschedule the event. Notice of the rescheduled event shall be given in the same manner as described in 5.1 to 5.2.

5.3 Insurance Requirements

- 5.3.1 CACC requires that all events be insured for liability and participant accident in coverage and amounts established by CACC.
- 5.3.2 The minimum insurance requirements for any event sanctioned by CACC are those minimum amounts as specified in the current master insurance plan of CACC.

5.4 Postponement/Cancellation

- 5.4.1 If the event is to be cancelled or postponed for any reason, CACC or its representative at their address must first be informed of the reasons for cancellation or postponement. Once cancellation is approved, all entry fees and other admission costs paid to the applicant or its agents by competitors/entrants will be fully refunded immediately or may be carried forward to the next event if requested by the competitor/entrant.
- 5.4.2 If the event is cancelled or postponed by reason of force majeure the event permit and any entry fees may be carried forward to an alternate date subject to that date being approved by CACC. If a competitor is unable to attend the future event arising from these circumstances, then their entry fees and any other admission costs will be fully refunded immediately.

- 5.4.3 If an event is cancelled prior to its commencement, the organizer will make reasonable efforts to inform all entrants, but neither the organizer, their series promoter or CACC shall accept any responsibility for any matters arising from the cancellation. Entry fees shall be returned to those not offered any opportunity to use the marked racetrack.

5.5 Credentials for CACC Officials

- 5.5.1 Organizers, as a condition of the granting of a CACC organizing permit, shall recognize CACC officials and their assistants. Vehicles, equipment and competition observers (maximum one (1) per designated flag station) shall be provided credentials and passes necessary to perform their functions.
- 5.5.2 Organizers shall assure access by CACC officials to the event control centre during the running of the event.

5.6 Notice on Official Documents

- 5.6.1 All event supplementary regulations, programs, entry forms and results relating to any CACC competition shall bear in a conspicuous manner the logo of CACC as well as the following announcement: "Sanctioned by CACC".

6 Event Regulations

6.1 Content of Event Regulations

6.1.1 Advanced Notice

The organizer of a CACC sanctioned event shall provide notice of a CACC sanctioned event to all Competitors not later than one (1) month prior to the event.

6.1.2 Form of Notice

Notification shall be given by mail or other means of distribution and the notice shall include information on at least the time and location of the event, and the time and location of registration and technical inspection if different from the event.

6.1.2.1 The dates of opening and closing of entries and how and where they shall be made and the penalty for late entry, if applicable, and the conditions under which entries may be refused.

6.1.2.2 The amount of the entry fee, the passes provided and the cost of additional passes to the entrants.

6.1.2.3 The location of the official noticeboard.

6.1.2.4 Entry forms shall contain the following:

6.1.2.4.1 Space for the full names and addresses of the entrant, driver(s) and crew members and the next of kin with telephone number, to be notified in case of emergency.

6.1.2.4.2 Space for the signature of the entrant and driver(s).

6.1.2.4.3 The following statement: "If an entrant, driver or crew member is under the legal age of majority, this form must be countersigned by the appropriate parent or legal guardian."

6.1.2.4.4 Indemnity and/or declaration as prescribed in Section 6.2 and signed by a person under the age of majority shall be countersigned by that person's parent or legal guardian whose full name and address must also be given. Space shall be provided for this purpose.

6.1.2.4.5 In addition, Minor's Assumption of Risk Acknowledgement Waiver, shall be signed by the competitor and by the competitor's parent or legal guardian.

6.1.3 Adequate Notice

6.1.3.1 Publication of a notice of a CACC event on the official CACC website shall be deemed sufficient as long as the website is updated by competitors not less than one (1) month before the event.

6.1.3.2 Event supplementary regulations, once approved by CACC, cannot be changed prior to the start of an event unless approved by the steward.

- 6.1.3.3 The event supplementary regulations shall contain:
 - 6.1.3.3.1 The name, place and dates of the proposed competition(s).
 - 6.1.3.3.2 The name, address and telephone number of the promoters and/or organizers.
 - 6.1.3.3.3 An announcement accompanied by the CACC logo; "Sanctioned by CACC".
 - 6.1.3.3.4 A full description of the proposed competition including length and direction of the course and categories of cars eligible to compete.

6.2 Required Indemnification

- 6.2.1 It is a condition of any insurance policy, whether CACC's insurance policy or otherwise, that waivers in the form specified by CACC be signed by all persons who participate in an event or who are permitted to enter areas normally closed to the public and/or paying spectators.
- 6.2.2 Only electronic or printed waiver forms available from CACC or its insurers are permitted. The signed waiver forms must be kept in safe storage by the organizer for a period of not less than two (2) years and shall be made available to CACC upon request.
- 6.2.3 Every entrant shall sign the following declaration before being permitted to take part in any competition. Such a declaration must be part of the entry form for the event:
 - 6.2.3.1 "I have read and familiarized myself with the CACC regulations and the event supplementary regulations and agree to abide by and be bound by them."
 - 6.2.3.2 "I further agree to ensure that the driver nominated by me and all crew members and guests are similarly familiarized with all regulations and agree to abide and be bound by them."
 - 6.2.3.3 "The entrant in signing this entry form and agreement and in consideration of the right to enter and compete in the event agrees to participate in the event and accept all risks. The entrant further agrees that the entrant, the driver and all crew members and guests shall each execute a release agreement prior to their admission to the event."
- 6.2.4 Indemnity and/or declaration as prescribed in Section 6.2 above which is signed by a person under the age of majority shall be countersigned by that person's parent or legal guardian whose full name and address shall be given. Spaces shall be provided by the organizer on the entry form or on a separate form, for this purpose.
- 6.2.5 It is hereby recognized by these regulations that the indemnities, declaration and undertaking given in Section 6.2 above may be subject to laws, statutes and regulations of the various provinces of Canada. Any amendment of these forms must have prior approval in writing from CACC.

6.3 Falsification of Entry

- 6.3.1 An entry containing a false or incorrect statement shall be null and void and the entrant may be deemed in a breach of these regulations and the entry fee shall be forfeited.

6.4 Event Schedule

6.4.1 An event schedule shall contain the following:

6.4.1.1 Date of event

6.4.1.2 Times and location of registration

6.4.1.3 Times and location of scrutineering

6.4.1.4 Times for each practice, warm up, qualifying and race session, as applicable

6.4.1.5 Number of laps for each race session or total time allowed for each race session, as applicable

6.4.1.6 Use of proper series names for all sessions

6.4.1.7 Times and location of any mandatory driver briefing

7 Conduct of Events

7.1 Unauthorized Practice

- 7.1.1 During a competition the organizer shall not permit a driver or car, nor shall the driver or car participate in, the use of a marked race track or solo events course at any time other than during the scheduled sessions for the competition entered. The only exception shall be for specific safety reasons and only with the approval of the clerk of the course.

7.2 Practice/Testing Before an Event

- 7.2.1 A driver and/or car shall not participate in the exclusive private use of a race track or solo events course within five (5) days prior to a race at that race track, determined from the scheduled day of the event.
- 7.2.2 If the race track or solo events course is available for testing or practice, all entered competitors in the competition must be permitted to participate on an equal basis.
- 7.2.3 It is the competitor's responsibility to determine whether or not a race track or solo events course is available for testing or practice.
- 7.2.4 CACC is not responsible for any accident or injury occurring during any pre-event testing as defined herein.
- 7.2.5 The scheduling of runs and/or race groups shall not be altered without the prior approval of the chief steward of the event, or in the event of force majeure.

7.3 Technical Inspection

- 7.3.1 Organizers are responsible for providing, and should make obvious to the entrants, an area for the inspection of vehicles prior to course entry.
- 7.3.2 Organizers are responsible for providing a means of positively indicating that vehicles have been inspected and approved for competition and ensuring that they are not permitted to enter the course without inspection.

8 Stewards

8.1 Stewards

8.1.1 Requirement of Stewards

At least one CACC appointed steward should be available for all or part of each CACC sanctioned competition. A steward must be present at all championship events. It is not interpreted by these GCRs that the steward must be present for the whole of the event, but they must be present at the time and place (or places) designated for the hearing of protests.

8.1.2 Assignment of Stewards

Stewards receive assignments from CACC.

8.1.3 Responsibility of the Stewards

They shall act primarily in a judicial capacity and therefore shall not incur any responsibility for the organization or execution of an event. A steward should not be a competitor at the event they are stewarding. When CACC has appointed one or more stewards, the steward appointed as the senior steward, shall act as chairperson of the stewards who shall act as a committee. The Senior Steward is, in particular, responsible for assigning stewarding duties, planning and holding meetings and for ensuring that the event report is prepared and submitted on time.

8.1.4 Authority of the Stewards

The steward shall be responsible for the general conduct of all sporting aspects of CACC competitions at an event, and to ensure conformity with all provisions of these regulations and relevant event supplementary regulations, and in addition shall settle any claim that might arise during a meeting, under reserve of the right of appeal.

8.1.5 The steward shall have authority in accordance with these GCRs to:

- 8.1.5.1 Settle any protest or dispute arising during an event, subject to the right to appeal.
- 8.1.5.2 Assess penalties of reprimand, fine, time, distance, probation or exclusion for breaches of these regulations, the Discipline Competition Regulations and event supplementary regulations and any other instructions as outlined in Section 2.5.
- 8.1.5.3 Apply penalties as necessary arising from protests, appeals and disciplinary hearings.
- 8.1.5.4 Prohibit from competing any driver or any vehicle considered dangerous.
- 8.1.5.5 Exclude from any one competition or from the event any driver or automobile which is considered to be ineligible to take part therein, or whom they consider guilty of misbehaviour or unfair practice.
- 8.1.5.6 Penalize and/or order the removal from the course and its precincts any entrant, driver, crew member or official found guilty of misbehaviour, unfair practice or who refuses to obey the order of a race official.
- 8.1.5.7 In case of force majeure or for reasons of safety either postpone, abandon, or stop a competition. If a competition is stopped, the steward may declare it "no contest" and arrange for it to be restarted or alternatively declare the event concluded and determine the results based on the competitors' positions at that time.

- 8.1.5.8 Appoint a temporary substitute or substitutes to replace any steward not able to perform his duties.
 - 8.1.5.9 Enquire into allegations of reckless or hazardous driving and, if appropriate, penalize the individual or refer the matter to CACC.
 - 8.1.5.10 Authorize amendments to the supplementary regulations for reasons of safety or force majeure.
 - 8.1.5.11 Authorize the alteration of composition or the consolidation of heats and/or sessions.
 - 8.1.5.12 Authorize a rerun in the case of tie runs.
 - 8.1.5.13 Authorize the change of driver or car.
 - 8.1.5.14 Authorize the modification of the program as to the position of the starting or finishing lines, race start procedures, or in any other manner, in accordance with a request of the organizer where necessary.
 - 8.1.5.15 Authorize a change in the program where such a change affects the race event.
 - 8.1.5.16 Authorize the amendment of the results of a competition based on a correction by the chief timekeeper or to take into account a penalty assessed against a competitor.
 - 8.1.5.17 At their discretion they may reclassify a vehicle that a competitor has incorrectly classified, provided it is a case of honest error.
- 8.1.6 Duties of Stewards
- 8.1.6.1 Ensures the course complies with the regulations.
 - 8.1.6.2 Ensures that the necessary standards for protection of competitors, spectators, and property are complied with.
 - 8.1.6.3 Ensures that all required safety equipment and personnel are present at the event.
 - 8.1.6.4 Shall be available to all competitors one (1) hour prior to the start of the event and must remain at the event until the grievance proceedings have concluded.
 - 8.1.6.5 Shall accept inquiries that are submitted in the proper form and within the specified time limits.
 - 8.1.6.6 Following receipt of an inquiry, the steward will normally note the time of receipt on the inquiry, return one (1) copy to the inquirer, give one (1) copy to the organizer, and retain the remaining copies.
 - 8.1.6.7 Receives the organizer's replies to all inquiries, transmits a copy of the reply to the original inquirer, and retains the remaining copies.
 - 8.1.6.8 Accepts protests that are submitted in the proper form and within the time limits specified and accompanied by the appropriate fee specified.
 - 8.1.6.9 Notes the time the protest was received, return one (1) copy to the protester, and bring the remaining copies to the protest hearing.

- 8.1.6.10 Upon receiving a protest, the steward first verifies that the protest has been properly submitted according to the GCRs. The steward then prepares a notice giving the location and time at which the protest hearing is to be held. This notice is to be posted next to the scoreboard. Notice is also to be given individually to each of the parties to the protest.
- 8.1.6.11 The steward conducts the protest hearing and renders a decision. If the decision is deferred, the steward may obtain such further evidence as he deems necessary, prepare his decision, and send it to the organizer.
- 8.1.6.12 If applicable, the steward may consider protests submitted to him by mail or email and then prepare a decision and send it to the organizer.
- 8.1.6.13 Accepts appeals that are submitted within the specified time limits and with the specified fee, noting the date and time of receipt on the appeal, return one (1) copy to the appellant, and post one (1) copy next to the scoreboard. Within twenty-four (24) hours after the conclusion of the event, the steward should send by mail or email copies of the appeal to the appropriate Discipline Director
- 8.1.6.14 Following the conclusion of the grievance proceedings, the steward may obtain one (1) copy of each grievance, reply, and notice, to be included with his report. The steward will retain all remaining copies for sixty (60) days in case they are needed as evidence at a later appeal hearing.
- 8.1.6.15 Provide a detailed event report to CACC within seventy-two (72) hours of the conclusion of the event, including, but not be limited to the following:
- 8.1.6.15.1 Copies of the supplementary regulations and official notices
 - 8.1.6.15.2 All event qualifying results
 - 8.1.6.15.3 All event race results
 - 8.1.6.15.4 Copies and details regarding any fines, penalties or reprimands issued or assessed, together with recommendations in respect of such cases
 - 8.1.6.15.5 Particulars of all protests lodged, action taken thereon,
 - 8.1.6.15.6 Payment on fines collected
- 8.1.6.16 The report may also contain the steward's general comments on the organization of the event and the exercise of their own powers in relation thereto, and any other observations as to the conduct of the event that they consider should be made to CACC.
- 8.1.6.17 The report should also contain a copy of the steward's instructions to the organizer and details of all accidents in which personal injury or property damage are believed to have occurred, detailing names and addresses of those involved.

9 Officials and their Functions

9.1 Event Officials

9.1.1 The staff of officials at each event shall include, but not be limited to the following:

9.1.1.1 Chief Organizer

9.1.1.2 Clerk of the Course (A.K.A. Race Director)

9.1.1.3 Chief timekeeper

9.1.1.4 Marshals

9.1.1.5 Starter

9.1.1.6 Scrutineer

9.1.2 The individuals referred to in the preceding section, shall be termed "officials" and may have assistants to whom any of their duties may be delegated.

9.2 Chief Organizer

9.2.1 The duties of the chief organizer may include those of the clerk of the course.

9.2.2 The chief organizer is responsible for the organization and general conduct of the event in accordance with the GCRs, the discipline regulations, and any supplementary regulations.

9.2.3 The chief organizer ensures that reasonable precautions have been taken with regard to spectator safety and that all spectator control measures are operational at all times. This includes course security, which is defined as maintaining control over spectator access to the course.

9.2.4 The chief organizer is responsible for the completion of all accident report forms.

9.3 Clerk of the Course

9.3.1 The Clerk of the Course's duties commence with the opening of the entries and conclude when the final results are posted. The clerk of the course must be present throughout all sessions in order to carry out the specified duties. In the case of a meeting comprising several competitions, there may be a different clerk of the course for each competition. In Karting, the Clerk of the Course may also be the Race Director. In events where a Steward is not assigned, the Clerk is responsible for the completion of the Steward Report to CACC.

9.3.2 In the case of all competitive events, the clerk of the course must hold a clerk of the course licence issued by CACC.

9.3.3 The clerk of the course is responsible for the general conduct of the meeting in accordance with these regulations, organizing permit and schedule and in particular, either directly or through delegation to:

9.3.3.1 Ensure that all relevant regulations are complied with and that all the equipment needed to do so is at hand or in use as appropriate.

- 9.3.3.2 Keep order in conjunction with such police authorities as have undertaken the policing of the meeting and who are especially responsible for public safety.
- 9.3.3.3 Ascertain whether all officials are at their posts and report the absence of any of them to the steward.
- 9.3.3.4 Ensure that all officials are provided with the information necessary for carrying out their duties.
- 9.3.3.5 Make arrangements to satisfy themselves that all drivers and entrants are in possession of the appropriate competition license, club membership card and medical certificate, (if applicable).
- 9.3.3.6 See that any competitor who cannot produce any document necessary to prove their eligibility at a meeting may only be allowed to start with the agreement of the steward on payment of a non- returnable fine.
- 9.3.3.7 Ensure that every accident or incident involving a competing vehicle is reported to the steward and Scrutineer and that the event medical officer shall be informed if any competitor is injured.
- 9.3.3.8 Ensure that no competing car or vehicle, which is to give a speed demonstration at a race or speed course shall, do so without the approval of the Scrutineer and that the driver has signed the waiver of release.
- 9.3.3.9 Shall control competitors and their automobiles and take appropriate action with regard to any competitor or automobile he may consider to be ineligible, undesirable, or dangerous.
- 9.3.3.10 Ensure that each vehicle and that, where appropriate, each competitor carries the proper credentials in accordance with the schedule.
- 9.3.3.11 Report to the steward that the conditions of the permit and track licence (where appropriate) have been fulfilled before the start of the event. Before making such a report the clerk of the course or a specified designate shall inspect the course and its installations.
- 9.3.3.12 Convey to the steward any proposal to modify the schedule or any report that deals with the misbehaviour of, or breach of rule by, a competitor or driver.
- 9.3.3.13 Receive any protests from competitors or drivers and immediately transmit them to the steward.
- 9.3.3.14 Collect all reports from timing and scoring, scrutineering, pit observers and observers as may be necessary for the determination of the results.
- 9.3.3.15 Prepare or arrange to prepare a written statement of the information necessary to enable the steward to complete their reports.
- 9.3.3.16 Report to the steward any competitor reported for ignoring flag signals.
- 9.3.3.17 Report to the steward any driver reported by race officials for careless, reckless or hazardous driving during a session.
- 9.3.3.18 Request the steward to exclude from the results a competitor for an offence for which such a penalty is specified in these regulations.

- 9.3.3.19 Ask the steward to impose a time penalty upon any competitor in a race meet who they consider has gained an unfair advantage, whether inadvertently or not. This regulation does not preclude such a competitor being reported to the steward for alternative penalties.
- 9.3.3.20 Make arrangements in conjunction with the event medical officer for medical checks in respect of drugs or alcohol to be carried out.
- 9.3.3.21 Ensure that any driver of the pace car during a session holds a pace car driver's licence.
- 9.3.3.22 Ensure that the correct driver is in each automobile and marshal the automobiles as necessary.
- 9.3.3.23 Send the automobiles to the starting line in the correct order and, if necessary, give the starting signal.

9.4 Chief of Timing and Scoring

- 9.4.1 At all competitions where competitors are timed there must be a chief of timing and scoring.
- 9.4.2 The chief of timing and scoring is responsible for the accurate timing of vehicles. The principal duties of the chief of timing and scoring are:
 - 9.4.2.1 Commence timing and scoring of competitions if so instructed by the clerk of the course. In the case of a handicap competition, where the handicap is applied at the start, the chief of timing and scoring is the deputy starter.
 - 9.4.2.2 In all qualifying and race events to use only such apparatus for timing as is approved by CACC or in the case of attempts at records where it is necessary to take times within one thousandth of a second.
 - 9.4.2.3 To register such times as are appropriate having regard to the conditions of the competition or as required by the clerk of the course.
 - 9.4.2.4 To prepare and sign their reports relating to the timing that is their individual responsibility and to send them with all necessary supporting documents, in the case of a meeting to the clerk of the course and in the case of an attempt at record to CACC.
 - 9.4.2.5 To send on request their original time sheets, laps charts and results either to the steward or to CACC.
 - 9.4.2.6 To communicate any times or results only to the steward and clerk of the course or in accordance with their instructions.
- 9.4.3 The chief timekeeper ensures that all timekeepers are in place and ready to start timing the competition when instructed to do so by the clerk of the course.
- 9.4.4 The chief timekeeper furnishes the clerk of the course and the steward any times and results they may request.
- 9.4.5 The chief timekeeper maintains records of official times for all competing vehicles.

- 9.4.6 Timing and scoring must not accept responsibility for ensuring the course is clear and that it is safe to permit the next competitor to start. The clerk of the course will appoint an official whose duty it shall be to notify timing and scoring when the course is ready for the next competition and ensure that timing and scoring are prepared for the next session.
- 9.4.7 Timing and scoring shall be responsible to the organizing club for all the timekeeping arrangements for the event.
- 9.4.8 The chief of timing and scoring will be a judge of fact in respect of timing and scoring matters at race events.

9.5 Starter

- 9.5.1 The starter operates directly under the supervision of the clerk of the course. All competing drivers are under the orders of the starter, from the time the cars are placed in their starting positions ready to start, until the competition is completed and all competing cars have left the course. It is the starter's responsibility to start the competition with the starting flag and end the competition with the checkered flag. The starter may also be required under the direction of the clerk of the course to display various other flags.
- 9.5.2 The starter is responsible for starting the cars off onto the course.
- 9.5.3 The starter provides flagging to drivers if necessary.
- 9.5.4 The starter is responsible either directly or through delegation, for staging vehicles, checking of technical inspections stickers, ensuring that the drivers are properly fastened in with seat belts and wearing helmets, and other aspects of the starting function. The starter may have assistants to help in these duties.

9.6 Scrutineer

- 9.6.1 Ensures the inspection for eligibility of all cars prior to the first track session and at any other subsequent time.
- 9.6.2 Reports to the clerk of the course the results of pre-race inspections and any subsequent inspections.
- 9.6.3 Inspects any cars damaged during track sessions.
- 9.6.4 Report to the clerk of the course any vehicle that is found not to conform to the requirements of the regulations.
- 9.6.5 The Scrutineer may re-inspect any and all vehicles that may become unsafe at any time during the event and conducts technical inspections at the request of the clerk of the course.
- 9.6.6 The Scrutineer shall not communicate any official information to any other person than the clerk of the course or steward.
- 9.6.7 Decisions of the Chief Scrutineer regarding safety matters are final and not subject to protest or appeal.

9.7 Marshals

- 9.7.1 All portions of the course must be visible to at least one marshal who can communicate through signals or by electronic means to the clerk of the course and/or the starter.
- 9.7.2 Each marshal shall be supplied with the required flag(s) by the chief organizer. These flags shall be used to communicate with the drivers while they are on the course and shall be deployed in order to ensure their maximum effectiveness.
- 9.7.3 Marshals are granted the powers of judges of fact in accordance with the duties of that position outlined in the GCRs.

9.8 Competition Observers

- 9.8.1 Observers may occupy posts around the course assigned to them by the clerk of the course and/or steward for purposes of reporting incidents that occur on the section of course being observed.
- 9.8.2 Marshals may also be designated as observers.

9.9 Judges of Fact

- 9.9.1 Judges of Fact may be appointed by the steward or the clerk of the course.
- 9.9.2 Starting judges point out to the steward any false starts immediately after they occur.
- 9.9.3 Finishing judges declare the order in which cars cross the start/finish line.
- 9.9.4 A protest may not be made against a decision of a judge of fact; however, a mistake by a judge of fact may be corrected by that judge of fact with the concurrence of the steward.

10 Flag Signals

10.1 Green Flag

10.1.1 Used by the starter to start all track sessions and by corner marshals to indicate that the track is clear. It should be waved at the marshal post immediately after the incident that necessitated the use of one or more yellow flags.

10.1.2 Some events may be started by using a light system.

10.2 Red Flag at Start/Finish and At All Posts

10.2.1 Should a decision be made to stop any track session, including a race, because of an accident or an incident, a red flag will be shown at the start/finish line and simultaneously each corner post will display a red flag.

10.2.1.1 Informs the driver that a track session has been halted. Drivers shall slow down immediately, no passing and proceed to the pits.

10.2.1.2 Cars entering the pits must remain in single file and stop in the pit lane away from the working area. If during a qualifying or race session, no work or service shall be performed on any cars until after the track has been reopened, except under the direction of the steward.

10.3 Black and White Chequered Flag

10.3.1 Used by the starter to cease all track sessions. The first driver to receive this flag during a race is in most cases the winner. Racing must stop and all drivers must slow down, complete one more lap and return to the paddock or other designated area.

10.4 Black Flag

10.4.1 With car number displayed, informs the driver to complete the current lap and stop for consultation in pit lane or at a location previously designated by the steward. If a driver fails to comply for any reason, this flag should not be shown for more than three consecutive laps. The decision to show this flag rests solely with the Steward(s).

10.4.2 This flag may also be displayed at places other than the start line, should the Clerk of the course deem this necessary.

10.5 Diagonal Black and White Flag with Car Number Displayed

10.5.1 Warns the driver of unsportsmanlike or unsafe conduct and that a penalty may be pending. Flag will only be shown once to any competitor as a warning. Any subsequent infractions will be dealt with using the black flag.

10.5.2 This flag may also be displayed at places other than the start line, should the Clerk of the course deem this necessary.

10.6 Black Flag with an Orange Disk with Car Number Displayed

- 10.6.1 Informs the driver of a mechanical problem likely to cause danger and to reduce speed and stop in pit lane for consultation at a location previously designated by the steward.
- 10.6.2 This flag may also be displayed at places other than the start line, should the Clerk of the course deem this necessary.

10.7 Yellow Flag

- 10.7.1 Any yellow flag is a signal of danger of any nature at or beyond the station displaying the flag.
- 10.7.2 Motionless: Take care, danger, slow down. No passing from the flag until past the emergency area and the green flag can be seen. Note: A driver may encounter several yellow flags before reaching the emergency area. The requirements are the same, slow down, no passing.
- 10.7.3 Waved: Great danger, slow down, be prepared to stop. No passing from the yellow flag until completely past the emergency area(s). Note: At an emergency area, there may be multiple cars involved in an incident. It is the driver's responsibility to not pass until fully past the emergency area(s) and the green flag can be seen.
- 10.7.4 Full Course Yellow: Great danger, slow down, no passing, be prepared to get into single file behind the pace car. A full course yellow may be indicated by the displaying of doubled stationary yellow flags by each corner station. Drivers should not rely on this distinction and must exercise appropriate caution if confronted by successive stations displaying single yellow flags, either waving or stationary. Except during a full course caution or when the Pace Car is on course, double yellow flags should not be displayed.
- 10.7.5 In every case, the end of the imposition of the speed limit will be indicated by a green flag at the next marshal post, or at each marshal post where appropriate. The sporting regulations for each race or championship may provide for the enforcement of these requirements.

10.8 Yellow Flag with Red Stripes

- 10.8.1 Advise the drivers to take care. Used to indicate a slippery surface such as the presence of oil, water and/or debris on the racing surface.

10.9 Blue Flag

- 10.9.1 Motionless: Another competitor is following very closely.
- 10.9.2 Waved: A faster competitor is trying to overtake.

10.10 White Flag

- 10.10.1 This flag should be waved and is used to indicate to the driver that there is a much slower vehicle on the sector of track controlled by that flag point.

10.11 Additional Flags

- 10.11.1 Certain Disciplines (such as Karting) may have specialized flags as identified in the Discipline Regulations.

11 Penalties

11.1 General

11.1.1 Any promoter, organizer, official, entrant, driver or other person committing a breach of these regulations and those described in Section 2.5.1 may be penalized.

11.1.2 Penalties should be noted in the driver competition logbook for future reference.

11.2 Breach of GCRs

11.2.1 Any of the following offences, in addition to any other offences specifically referred to previously or hereafter, is a breach of these GCRs:

11.2.1.1 Bribery or attempt to bribe anyone connected with the competition and the acceptance of, or offer to accept, a bribe.

11.2.1.2 Any action having as its objective participation in the competition of a person or automobile known to be ineligible.

11.2.1.3 Any fraudulent proceeding or act prejudicial to the interests of CACC or of automobile competition generally.

11.2.1.4 Reckless or unsafe driving or other driving infractions as defined in the applicable regulations.

11.2.1.5 Failure to obey directions or orders of event officials.

11.2.1.6 Refusing to co-operate with, interfering with, or obstructing the actions of the steward or court of appeal in the performance of their duties.

11.2.1.7 Abusive language or behaviour within the area under control of the organizing club.

11.2.1.8 Failure to honour a cheque payable to CACC or to a CACC club or event organizer.

11.3 Repeated Violations

11.3.1 Repeated breaches of these regulations are subject to an increase in severity of the penalty imposed for each subsequent occurrence.

11.3.2 In case of incidents that involve multiple violations, consecutive penalties may be imposed.

11.4 Penalties for Participation in Unsanctioned Competition

11.4.1 Any person or body who shall promote, enter for, drive in, officiate at, or in any manner whatsoever take part in, or advertise, or obtain publicity for the results of, a competition not organized, recognized or held in accordance with all respects with these GCRs; or who shall become disqualified or suspended by the governing body of any other sport recognized by FIA may be disqualified or suspended and shall thereby forfeit their right to:

11.4.1.1 Hold a competitor's or driver's licence.

11.4.1.2 Hold any official appointment in connection with CACC or in connection with any competition.

- 11.4.1.3 Be ineligible for participation in competitive events for such time as CACC may deem appropriate.

11.5 Imposition of Penalties

11.5.1 The penalties which may be inflicted are, in order of increasing severity, as follows:

- 11.5.1.1 Reprimand (which may be verbal or written)
- 11.5.1.2 Fine
- 11.5.1.3 Penalty of Time or Distance
- 11.5.1.4 Probation of CACC competition privileges.
- 11.5.1.5 Exclusion from a competition or event
- 11.5.1.6 Loss of accrued points.
- 11.5.1.7 Suspension
- 11.5.1.8 Disqualification

11.5.2 Combinations of penalties may be assessed.

11.6 Sentence of Reprimand or Fine

11.6.1 A reprimand or a fine may be imposed by the CACC steward or by CACC. The maximum amount of a single fine is \$10,000. A fine may be inflicted on any entrant, driver, assistant, or passenger who does not comply with the requirements of any regulation or with any instruction of the officials. A reprimand against a CACC licensed driver should be noted in the driver's licence file as should be any or all other penalties.

11.7 Time Limit for Payment of Fines

- 11.7.1 Fines shall become due and payable within seventy-two (72) hours after their being ordered. Any delay in making payment may entail suspension for the period during which a fine remains unpaid.
- 11.7.2 Failure to honour a cheque payable to CACC will result in suspension of the entrant's or driver's competition privileges until full payment of the fine, bank charges, and an additional service charge of \$50.00 has been paid.

11.8 Allocation of Proceeds from Fines

11.8.1 The proceeds from all fines, forfeited protest fees, and appeal fees shall be remitted to CACC.

11.9 Penalty of Time

11.9.1 A time penalty may be imposed by the steward on any driver who does not comply with the requirements of any regulation or with any instruction of the officials of the meeting. If the penalty is assessed during the running of the competition, notice of the penalty must be given to the entrant or driver as soon as practicable. Supplementary regulations may specify the amount of penalty for certain infractions.

- 11.9.2 Time penalties in seconds, or minutes and seconds, may be imposed by the steward or by appeal proceedings. "Stop-and-go" penalties and exclusion penalties shall be considered to be time penalties.

11.10 Distance Penalty

- 11.10.1 A penalty may be in the form of one (1) or more laps. Competitors may be penalized by the steward or as a result of appeal proceedings.

11.11 Probation of CACC Competition Privileges

- 11.11.1 Probation may be imposed by the steward or CACC for a period of no more than six (6) months. This probation may also restrict a driver to certain types of events or specify other conditions. Failure to comply with the probation is grounds for further penalties. A sentence of probation may be reviewed by CACC before the expiration of its term.

11.12 Sentence of Exclusion

- 11.12.1 A sentence of exclusion may be pronounced by the steward or by CACC and may be retroactive. Before imposing a sentence of exclusion, the steward or CACC, as the case may be, must summon the party concerned before them and afford them the opportunity of giving their own evidence. If the hearing is to be held at an event, officials must deliver written notice personally to the party concerned or the entrant. If the hearing is to be held at a later date, the summons may be delivered personally or by mail or email and must give reasonable notice and a reasonable opportunity for the party concerned to attend. A person, body, or automobile shall be liable to sentence of exclusion:

11.12.1.1 If shown to have been forbidden by the proper authority to take part in the event, or

11.12.1.2 Having taken any part in any competition, if shown to have been ineligible to do so, to have been eliminated therefrom, or to have been forbidden by the proper authority to participate in any award in or to be placed therein.

11.12.1.3 If considered by the steward or the officials to be guilty of misbehaviour, unfair practice, or a violation of regulations. Any entry fee paid by or in respect of the person, body, or automobile sentenced shall be forfeited to the organizers or promoters.

11.13 Loss of Accrued Points

- 11.13.1 Loss of accrued points may be imposed by CACC. Such loss may be recommended by the steward or CACC.

11.14 Sentence of Suspension

11.14.1 A sentence of suspension may only be pronounced by CACC and shall be reserved for grave offences.

11.14.2 A person, body, automobile, or make of automobile shall be subject to suspension when, for a certain period, forbidden by the proper authority to take part in any competition within the territory of CACC.

11.14.3 Suspension shall render void any entry made for a competition taking place during such suspension and any entry fee paid or payable shall be forfeited to the organizers or promoters.

- 11.14.4 Where a sentence of suspension relates to a competitor or driver, they shall immediately send their licence to CACC. The licence shall be retained by CACC until the suspension expires.
- 11.14.5 Delay in handing in a licence in accordance with the preceding subparagraph of this regulation shall automatically result in the extension of the suspension by a period equal to the delay.
- 11.14.6 Before imposing a sentence of suspension, the party concerned must be summoned either personally, in writing, or by mail or email giving reasonable notice and reasonable opportunity to attend a hearing at which they will be afforded the opportunity of presenting their own evidence or calling witnesses in defence or mitigation.

11.15 Sentence of Disqualification

- 11.15.1 A sentence of disqualification may be pronounced by CACC and shall be reserved for exceptionally grave offences.
- 11.15.2 A person, body, automobile, or make of automobile shall be subject to disqualification when expressly forbidden by the proper authority to take part in any CACC competition whatsoever.
- 11.15.3 Where the sentence of disqualification relates to a competitor or driver, they shall immediately return their licence to CACC.
- 11.15.4 Disqualification shall render void any previous entry made for any competition and any entry fee paid or payable shall be forfeited to the promoters or organizers.
- 11.15.5 Before imposing a sentence of disqualification, the party concerned must be summoned to a hearing either personally, in writing, or by mail or email giving reasonable notice and reasonable opportunity to attend a hearing at which they will be afforded the opportunity of presenting their own evidence or calling witnesses in defence or mitigation.
- 11.15.6 A sentence of disqualification shall be pronounced for the violation of regulation 2.4.1.3 of these regulations.

11.16 Statement of Reasons for Suspension or Disqualification

- 11.16.1 In notifying sentences of suspension or disqualification to CACC it shall be necessary to give its reasons for inflicting such a penalty.

11.17 Suspension or Disqualification of Automobiles

- 11.17.1 A sentence of suspension or disqualification may be pronounced on either a particular automobile or on a make or automobile.

11.18 Disciplinary Action

- 11.18.1 Participants who display a disregard or repeated disregard for these regulations or those other regulations as described in Section 2.5.1 or who by their conduct display unsportsmanlike behaviour are subject to disciplinary proceedings.
- 11.18.2 CACC at its discretion may commence a disciplinary action at a competition.
- 11.18.3 The results of a disciplinary action are final, and any orders or penalties applied to a competitor are binding upon the parties.

11.19 Loss of Award

11.19.1 Any competitor who may be excluded, is suspended, or disqualified in any competition shall then forfeit all rights to awards in that competition.

11.20 Amendment of Placings and Awards

11.20.1 In cases of exclusion, suspension or disqualification, the steward or CACC imposing the penalty shall declare the resulting amendment to the placings and awards and they shall decide whether the next competitor in order (after those placed) shall be advanced.

11.21 Publication of Penalty

11.21.1 CACC shall have the right to publish or cause to be published a notice stating that it has penalized any person, body, automobile, or make of automobile and, if it so desires, the reasons therefore.

11.21.2 The person(s) or body referred to in such notice shall have no right of action against CACC or against any person publishing or printing the notice and may incur disqualification if such action is taken.

11.22 Remission of Sentence

11.22.1 CACC shall have the right to remit the unexpired term of a sentence of suspension or disqualification inflicted under these GCRs on such conditions (if any) as it may deem appropriate.

12 Inquiries

12.1 Inquiries

- 12.1.1 A steward (or another official designated for the purpose) shall be available at the event to receive written inquiries. A written record shall be made of all inquiries, including the date and time received, as well as a summary of their content. The inquiry shall then be passed to the organizer (or another official designated for the purpose) for disposition.
- 12.1.2 Any inquiry from a competitor concerning their time or placing must be submitted within thirty (30) minutes of the time it was posted.
- 12.1.3 Any other type of inquiry from a competitor must be submitted within thirty (30) minutes of the completion of the last official timed run.
- 12.1.4 Inquiries must refer to the pertinent section of the appropriate regulations.

12.2 Replies to Inquiries

- 12.2.1 The organizer's reply to an inquiry must be submitted to the steward within thirty (30) minutes of the time the inquiry was given to the organizer by the steward.
- 12.2.2 The steward may grant an extension to the organizer's allowable time to reply to an inquiry in order to make it physically possible for the organizer to prepare his reply.
- 12.2.3 If the steward believes that sufficient extension has been granted to the organizer, or if the inquirer so requests, he shall retrieve the inquiry from the organizer, mark it "VOID," mark the time on it, and return it to the competitor. (It should be noted that in so doing the steward voids the competitor's opportunity to have the inquiry answered by the organizer. However, in so doing, the competitor's right to protest remains unaffected.) Alternatively, where the object of an inquiry concerns a dispute between two (2) or more competitors and should one (1) or more of the affected competitors so request, the inquiry will be declared void and the procedure may be bypassed. Should this occur, the original inquiry will only be acted upon if the inquirer files a formal protest.
- 12.2.4 Replies to inquiries must refer to the pertinent section of the appropriate regulations.

13 Protests

13.1 The Right of Protest

- 13.1.1 The right to protest lies solely with entrant and drivers who may consider themselves aggrieved by any decision, act or omission of a promoter, organizer, official, entrant, driver or any other person connected with any competition in which they are taking part, except that there shall be no right to protest against refusal of an entry, nor where otherwise expressly prohibited by these regulations.
- 13.1.2 The onus is at all times on the entrant or driver, as the protester, to establish the exact terms of the protest.
- 13.1.3 The right to protest shall be predicated only on a protest being well founded. The steward shall review the submitted protest and deem them well founded or not.
- 13.1.4 A well-founded protest is defined as being reasonable, logical, based on relevant facts and supported by relevant evidence.
- 13.1.5 A fact is defined as something that can be proven and evidence is defined as that which supports fact, logic or reason.
- 13.1.6 Protests that are deficient in reason, logic, facts or evidence may be deemed as not well founded and may be denied by the steward and the protest fee retained.
- 13.1.7 Hearsay, conjecture, and unsupported opinion may be considered vexatious.
- 13.1.8 Protests that are deemed not well founded may also be vexatious and may be denied. In such instances the protest fee shall be retained, and further penalties may be applied.
- 13.1.9 Drivers must remain at a competition and be easily contacted until any protest period relating to their competition has elapsed. No substitute representation is permitted.
- 13.1.10 Participants involved in a dispute or protest shall remain at the racetrack for the protest period and for any reasonable period of time beyond as may be requested by the steward.
- 13.1.11 Competitors who do not comply or cannot be easily contacted, are subject to judicial proceedings and penalties being applied in their absence. In such cases where penalties are applied, the possibility of appeal is forfeited. Any penalty applied shall remain in force.
- 13.1.12 Nothing in these regulations shall affect or prejudice the right and duty of any race official to make such action as deemed proper in any circumstances, regardless of whether a protest has been lodged.
- 13.1.13 Decisions of any judge of fact are not subject to protest or appeal.
- 13.1.14 Decisions of the steward are not subject to protest, only to an appeal.
- 13.1.15 It is the protester's responsibility to understand and comply with these protest procedures and no claim for misunderstanding of any kind will be accepted.

13.2 Protest Fees

- 13.2.1 The protest fee shall be \$50.00 for Autoslalom or Time Attack events, \$100 for Race, Ice Race or Vintage events, \$500 for Kart events, or as determined by CACC Discipline Regulations.
- 13.2.2 The protest fee must be held by the steward until the time limit for submission of an appeal has expired.
- 13.2.3 Costs of the hearing may be assessed by the steward against the protesters, the protested, and/or the organizing body.
- 13.2.4 The steward shall determine the disposition of all fees as follows:
 - 13.2.4.1 If the protest is deemed to be not well founded, the fee may be retained by CACC.
- 13.2.5 If the steward determines that a protest requires dismantling components of a vehicle to facilitate technical inspection, they may order that a reasonable teardown bond be posted with the stewards by the protester. The amount of the bond shall be decided by the steward but shall be a minimum of one thousand (\$1000.00) dollars. If the protest is upheld, the bond shall be returned to the protester. If the protest is denied, the steward shall rule that some or all of the bond be given to the protested. Portions of the bond not given to the protested shall be returned to the protester.
- 13.2.6 If the protest is deemed vexatious, the protester shall be deemed guilty of a breach of these regulations and shall forfeit the protest fee and may be further penalized for this breach.

13.3 Submission of a Protest

- 13.3.1 Every protest shall be made in writing, and:
 - 13.3.1.1 Specify which part(s) of these regulations, class regulations or event supplementary regulations are considered to have been violated and by whom.
 - 13.3.1.2 Provide names of witnesses, if any.
 - 13.3.1.3 Provide videotape evidence, if involved.
 - 13.3.1.4 Be signed by the entrant or driver making the protest.
 - 13.3.1.5 Accompanied by the appropriate protest fee payable to CACC. Such fee shall only be returned if the protest shall be deemed well founded or if so directed by the steward judging the protest.
 - 13.3.1.6 Delivered to the steward within the time limit specified within these regulations.

13.4 Time Limits for Protests

- 13.4.1 The steward may extend a time limit, but only for reasons of force majeure. Otherwise, for a protest to be considered, it must be lodged with the steward in accordance with the following time schedule.
 - 13.4.1.1 When the alleged ineligibility of a car, or a component of a car is apparent, within thirty (30) minutes after the end of the track session in which the alleged infraction is observed or in the case of Time Attack or Autoslalom Events, the final timed run.

- 13.4.1.2 When the alleged ineligibility is not apparent, but it is alleged that the car is performing in a manner which suggests that it is ineligible, within thirty (30) minutes after the end of the track session in which the infraction is alleged to have occurred, unless otherwise specified in series regulations, or in the case of Time Attack or Autoslalom Events, the final timed run.
- 13.4.1.3 A protest against any occurrence or irregularity while a practice, qualifying or race session was in progress, within thirty (30) minutes of the end of the track session in which the infraction is alleged to have occurred, or in the case of Time Attack or Autoslalom Events, the final timed run.
- 13.4.1.4 A protest concerning the results of a qualifying session, within thirty (30) minutes of the posting of the results of the session.
- 13.4.1.5 A protest concerning the provisional results of a race, within thirty (30) minutes of the posting of the provisional results of a race.
- 13.4.1.6 A competitor who believes that an error has been made in the distributed results (where those distributed results are at variance with the posted results) may submit a protest concerning the error by mail or email. A full statement of the protest shall be sent by mail or email to the steward (accompanied by the appropriate fee) with a copy to the organizer within fifteen (15) days of the mailing or distribution of the results.
- 13.4.1.7 If the reply to an inquiry is unsatisfactory to a competitor or if the inquiry has been voided as above, they may submit a protest concerning the same matter as the inquiry within thirty (30) minutes of the completion of the last official timed run, within thirty (30) minutes after the time the reply was received, or within thirty (30) minutes after the time the inquiry was voided, whichever is later.
- 13.4.1.8 If a competitor wishes to submit videotape of an incident in support of a protest, it shall be surrendered in its original, unedited format to the Steward within thirty (30) minutes of the end of the session in which an incident is alleged to have occurred.
- 13.4.1.9 If a competitor wishes to submit videotape of an incident in defence of a protest, it shall be surrendered in its original, unedited format to the steward within thirty (30) minutes of the notification of the protest to the competitor.

13.5 Protest Meetings

- 13.5.1 If a protest is submitted as specified, a protest hearing must be held at the conclusion of the event.
- 13.5.2 Upon receiving the written protest, the steward shall verify that the protest has been properly submitted in accordance with the regulations and then post a protest notice or notify all parties to the protest.
- 13.5.3 Failure of the protester to comply with all of these conditions shall result in the return of the protest without hearing and the retention of the protest fees by CACCC.
- 13.5.4 The number of stewards that shall judge a protest is as follows:
 - 13.5.4.1 One or three stewards for an event.
 - 13.5.4.2 The above requirements are notwithstanding that a greater or lesser number of stewards may have been present for all or part of an event.

- 13.5.4.3 Stewards who sit in judgment of protests must not have acted in any official capacity at the event, where executive power (other than as a steward) was a part of their office.
- 13.5.5 The protest hearing shall not be held sooner than thirty (30) minutes after the notice of the hearing is posted.
- 13.5.6 During the protest hearing, all persons wishing to present evidence shall be allowed to do so.
- 13.5.7 Protesters at a hearing shall themselves, or with the assistance of a designated translator if language difficulties exist, state their case in person and are entitled to call witnesses and shall be responsible for the prompt availability of any witnesses called.
- 13.5.8 The onus is always on the protester to properly present a protest and no claim based on lack of knowledge of these regulations, class regulations, or event supplementary regulations shall be allowed.
- 13.5.9 Should a protester designate a translator for purposes of stating or arguing a protest, the words of the translator shall be deemed to be those of the protester.
- 13.5.10 In the absence, or undue delay in attendance, of any party to a protest, judgment may proceed by default.
- 13.5.11 A protest hearing concerning an error in the distributed results shall be held within fifteen (15) days of the steward's receipt of the protest.
- 13.5.12 Following the protest hearing, the steward shall prepare a reply. The reply shall contain his decision and shall state specifically what changes are to be made to the scores as a result of the decision. Copies of the reply shall be distributed to all parties affected by the decision or otherwise concerned.

13.6 Video Evidence

- 13.6.1 Competitors submitting video shall provide at the same time the means to view the video or the video shall not be allowed as evidence.
- 13.6.2 The steward reserves the right to preview video and decide on its acceptance as evidence. This decision shall be final and binding on all parties for the purposes of a protest.
- 13.6.3 Should a video be considered as valid evidence the competitor and/or entrant involved shall be allowed to view the video only in the presence of the steward or a designate.
- 13.6.4 Once a video has been submitted as evidence it shall be impounded, whether accepted as evidence or not, until the time limit for giving notice of intention to appeal has passed and such notice has not been given.
- 13.6.5 In the event that a notice of intention to appeal is given, the video or a copy of the original created by a method approved by CACC will be held by CACC until the appeal hearing is conducted.
- 13.6.6 The steward shall have the final decision to accept the video and equipment to view same on. The minimum television size shall be a twelve inch (12") colour screen. Decisions of the steward are final and not subject to protest or appeal.

13.7 Protest of a Race Car

- 13.7.1 Only entrants and drivers entered in an event may protest the eligibility of another car.
- 13.7.2 In such cases the protest shall clearly state the exact regulation(s) alleged to have been violated and shall additionally stipulate the component(s) that are to be inspected.
- 13.7.3 The protester shall be required to post a cash bond with CACC in the amount determined by the steward, which amount shall be sufficient to cover the costs of any disassembly, inspection and re-assembly by a qualified service technician.
- 13.7.4 Such inspection shall be performed under the supervision of CACC.
- 13.7.5 If a decision based on the inspection gives rise to an appeal by either party to the protest, the cash bond shall be retained until a final decision is made.
- 13.7.6 If the car is found not to conform to these regulations or those of the class regulations, the cash shall be returned to the protester and all inspection costs shall be borne by the entrant and/or driver of the inspected cars.
- 13.7.7 If the car is found to be in conformity, the protester will forfeit the cash bond to CACC to cover the inspection costs involved. Any amount remaining after payment of costs will be returned to the protester.
- 13.7.8 Failure of the entrant and/or driver of a protested car to allow inspection under the terms of this regulation shall result in immediate exclusion and other penalties.
- 13.7.9 A protest under this regulation may be reduced in scope by the protester, but not added to, at the time the bond is set. Once a bond is posted, the stipulated inspections must be completed, except if entirely or partially withdrawn by the protester before the inspection begins.
- 13.7.10 If a protest under this regulation is withdrawn completely by the protester prior to the commencement of the inspection, the steward shall return the cash bond to the protester less an amount to be determined by the steward, but in no case shall the retained amount be less than \$50.00.

13.8 Re-Run

- 13.8.1 Neither the steward nor CACC shall have the power to order a competition to be re-run.

13.9 Distribution of Awards

- 13.9.1 Excepting any post-race victory awards presentations, which are unofficial, distribution of awards shall not commence until after the period for protests has elapsed. When a protest which would affect distribution of awards has been lodged, distribution shall be withheld pending the decision of a protest or appeal hearing. During this time, the results of the competition shall be considered provisional.
- 13.9.2 The distribution of prizes shall not commence until the results are final or unless the award winners will not be affected by any pending protests or appeals.
- 13.9.3 Where a protest is lodged, the distribution of a prize must, if the entitlement to the prize may be affected by the decision of the adjudicators, be withheld until the protest has been adjudicated upon and either the results of any possible appeal arising out of such adjudication are known or the time limit for notice of appeal has expired without notice of appeal having been given. The list of awards insofar as it relates to such a prize must be declared to be provisional.

- 13.9.4 If after the distribution of prizes a decision is made pursuant to these GCRs, which affects the results of a competition, any competitor to whom a prize has been awarded but who is adjudged to be ineligible therefore shall return such prize to the promoters or organizers on demand.

13.10 Distribution of Prizes

- 13.10.1 The distribution of prizes shall not commence until the results are final or unless the award winners will not be affected by any pending protests or appeals.
- 13.10.2 Where a protest is lodged, the distribution of a prize must, if the entitlement to the prize may be affected by the decision of the adjudicators, be withheld until the protest has been adjudicated upon and either the results of any possible appeal arising out of such adjudication are known or the time limit for notice of appeal has expired without notice of appeal having been given. The list of awards insofar as it relates to such a prize must be declared to be provisional.
- 13.10.3 If after the distribution of prizes a decision is made pursuant to these GCRs, which affects the results of a competition, any competitor to whom a prize has been awarded but who is adjudged to be ineligible therefore shall return such prize to the promoters or organizers on demand.

13.11 Judgment from a Protest Hearing

- 13.11.1 All parties concerned shall be bound by the decision given, subject only to the appeal proceedings as provided in these regulations.

13.12 Publication of Judgments

- 13.12.1 CACC shall have the right to publish or cause to be published a judgment of a protest and to state the names of all parties involved. The persons or bodies referred to in such notice shall have no right of action against CACC, or against anyone printing or publishing said notice.

14 Appeals

14.1 Request for an Appeal

- 14.1.1 Except where excluded in these regulations, an entrant or driver may submit a request for an appeal of a decision that was rendered by the steward.
- 14.1.2 A request for an appeal does not mean the appeal will be allowed automatically.
- 14.1.3 Appeal proceedings of CACC are designed to expedite sporting disputes in a timely and efficient manner and do not necessarily follow practices or formalities normally associated with those of the legal profession.
- 14.1.4 It is the appellant's responsibility to understand and comply with these appeal procedures and no claim for misunderstanding of any kind will be accepted.

14.2 Ground for Appeal Requests

- 14.2.1 The grounds for a request for an appeal are any of the following allegations:
 - 14.2.1.1 The steward has dealt with the case using improper procedures.
 - 14.2.1.2 New substantial evidence and/or expert testimony relating to the case that could not have been readily available at the time of the application of the original decision by the steward.
- 14.2.2 An appeal will not be granted for a repeat presentation of the original protest.

14.3 Time Limit

- 14.3.1 Notice of the intention to submit a request for an appeal shall be given to the steward within one (1) hour of the verbal announcement of the steward's decision and shall be accompanied by a cheque payable to CACC in the amount of \$200.00.
- 14.3.2 A request for an appeal, signed by the appellant, must be submitted in an absolutely clear and legible form; otherwise it may be denied without further action taken.
- 14.3.3 A request for an appeal must be submitted to the CACC office where it must be received within seventy-two (72) hours after the submission to the steward of the notice of intention to submit a request for an appeal hearing.
- 14.3.4 A request for an appeal may be withdrawn with the agreement of CACC. The appeal fee shall be returned to the appellant less a minimum of \$50.00 to cover the costs.

14.4 Effect of Requesting an Appeal

- 14.4.1 Notice of request for an appeal shall not affect the validity of enforcement of any decision, penalty or sentence appealed against.
- 14.4.2 The steward, if notified of intention to submit a request for an appeal, may permit a competitor to continue to participate in a competition if the matter arises during the course of an event.

- 14.4.3 This decision itself is not appealable and in any event the steward shall order awards which may be affected by the outcome of the appeal to be withheld pending the outcome of a request for an appeal.

14.5 Required Submissions

- 14.5.1 A request for an appeal shall only be submitted in person, by mail, email, or courier.
- 14.5.2 A request for an appeal must contain sufficient information to allow CACC to determine how a dispute will be managed and whether or not formal appeal proceedings will take place. Failure of the appellant to provide sufficient information will result in the rejection of the appeal without a hearing and forfeiture of the appeal fee.
- 14.5.3 A request for an appeal shall specify in full:
- 14.5.3.1 The grounds for claiming that the steward acted improperly, clearly indicating which part(s) of any regulations are considered to have been enforced in a manner that was not fair or equitable to the appellant.
 - 14.5.3.2 A complete description of any new evidence and/or expert testimony and how it may affect the original protest decision.
 - 14.5.3.3 A list of witnesses that the appellant may wish to call, a description of their involvement in the incident in questions and the general nature of their testimony.
 - 14.5.3.4 The request for an appeal shall bear the signature of the appellant or an authorized representative of the appellant accompanied by a letter authorizing the representative to act on behalf of the appellant and shall include the address to which communication should be sent with a telephone number and a fax phone number.
 - 14.5.3.5 CACC reserves the right to preview any videotape submitted and decide on its acceptance as evidence. This decision shall be final.

14.6 Decision to Grant an Appeal

- 14.6.1 CACC alone will decide if a request for an appeal is well founded. Should an appeal not be granted, the appeal fee will be returned less a \$20.00 administration fee.
- 14.6.2 CACC reserves the right to settle any dispute that may be referred to in a request for an appeal without submitting the case to appeal proceedings.
- 14.6.3 Should CACC deem that a request for an appeal is vexatious in nature, the entire appeal fee will be forfeit and further penalties may be applied.
- 14.6.4 Decisions made under this regulation shall be final and binding upon the appellant and not subject to further action.

14.7 Appeal Proceedings

- 14.7.1 An appeal may be handled administratively by CACC without a formal hearing.
- 14.7.2 When a formal hearing is deemed necessary by CACC, an appeal chairperson will be appointed by CACC. The appeal chairperson will attempt to convene and hear the appeal no later than one (1) week after CACC's decision to grant an appeal hearing.

- 14.7.3 Notice to the appellant indicating the time and place for the hearing will be given. It is incumbent upon the appellant to assemble any witness at the appointed place and time.
- 14.7.4 At a formal appeal hearing the appellant may present evidence and may call witnesses. The appellant may have counsel present with the permission of the appeal chairperson but must always present their case personally.
- 14.7.5 An appellant may submit the case to the appeal chairperson entirely in writing without personal appearance.
- 14.7.6 The appeal chairperson may hear evidence and witnesses in any manner deemed by the appeal chairperson to be appropriate, relevant or necessary.

14.8 Provision for Expedited Appeal

- 14.8.1 CACC may arrange at its discretion the alteration of the appeal process so as to provide an expedited appeal.
- 14.8.2 An expedited appeal may be dealt with by CACC immediately after a decision of the steward has been given and a notice of intention to submit a request for an appeal has been given to the steward by the appellant.
- 14.8.3 The results of such an expedited appeal shall be final and binding on all parties.

14.9 Jurisdiction of Appeal Proceedings

- 14.9.1 CACC appointees to appeal proceeding shall not participate or sit in judgment if they have taken part as competitors, officials, organizers, promoters or sponsors in the competition which involves the subject of the appeal or who have been directly involved in the matter under consideration.

14.10 Judgment of Appeal Proceedings

- 14.10.1 After considering the material deemed relevant to reach a decision, an appeal chairperson shall prepare a written judgment. An existing penalty may be nullified, mitigated, affirmed, increased or a different penalty imposed. A competition cannot be rerun, nor an event schedule revised.

14.11 Judgment Is Final

- 14.11.1 Appeal judgments constitute the final court of appeal to settle any dispute arising out of or in connection with a competition and no further action may be taken by the appellant.

14.12 Publication of Judgments

- 14.12.1 CACC shall have the right to publish, or cause to be published, a judgment of an appeal and to state the names of all parties involved. The persons or bodies referred to in such a notice shall have no right of action against CACC or against anyone printing or publishing said notice.

14.13 Conduct after Judgment

- 14.13.1 Any participant who, subsequent to an appeal judgment, discredits or attempts to discredit the judgment shall be subject to disciplinary action.

15 Insurance Requirements

15.1 Insurance Requirements

Such amounts as may be in effect under the CACC Master Insurance Plan for the current competition year.

15.2 Ice Race Event Insurance Exclusions

If insurance for an ice race event has been obtained through the CACC master insurance policy carrier, the following exclusion is specifically in force:

"The insurance policy does not apply to **bodily injury, property damage or public liability** arising out of melting, breaking or collapsing of ice on which racing programs are staged." The above exact wording must appear on all entry forms and event permits for ice race events sanctioned by CACC.

Member clubs are recommended to post at least one (1) sign informing everyone entering the race site of this exclusion.

16 Roll Cage Specifications

16.1 General Requirements

- 16.1.1 Unless specified otherwise in series, event or class regulations, all vehicles regardless of date of manufacture must be fitted with an eight (8) point roll cage conforming to the following specifications:
- 16.1.1.1 The top of the roll bar shall be at least 5.08 cm (2") above the top of the competitors' helmet or as close to the roof as possible. The top of the roll bar shall be no more than 25.4 cm (10") behind the competitor's helmet when the competitor is in the normal driving position. In the case of open cockpit cars without a windshield frame, the top of the front hoop may be under, but as close to the height of the front cowling as possible and be above the top of the steering wheel. It should be possible to draw a line connecting the front and rear hoops and have it pass above the driver's head when seated in the normal driving position.
 - 16.1.1.2 All portions of the roll cage subject to contact by the driver must be padded with a minimum 1 inch of material or padding that meets or exceeds SFI 45.1 or FIA 8857-2001 (curved padding), or SFI 45.2 or FIA sports car headrest material (flat padding) specification.
- 16.1.2 Vintage racing vehicles built and raced before January 1, 1980 with a rollover bar may be raced as is provided the mounting structure is acceptable. Any vintage racing vehicle prepared after this time must be fitted with a roll cage complying with the current CACC requirements.

16.2 Construction Materials

- 16.2.1 Seamless or DOM mild steel tubing (SAE 1020 or 1025 recommended) or alloy steel tubing (SAE 4130) must be used for all roll cage structures. Alloy and mild steel tubing may not be mixed. ERW tubing is not allowed.
- 16.2.2 Aluminum and composite materials are prohibited construction materials for roll cage structures.
- 16.2.3 All cages must have a 0.476 cm (.1875") diameter inspection hole drilled in each main hoop.
- 16.2.4 The following table shows the minimum allowed tubing outer diameter and wall thickness by vehicle weight:

Vehicle Weight as Raced with Driver	Tubing Size (inches) (outer diameter x wall thickness)
Up to 1700 lbs.	1.375" X .080"
1701 – 2699 lbs.	1.500" X .095" 1.625" X .080"
2700 lbs. and up	1.50" X .120" 1.750" X .095" 2.00" X .080"

16.3 Fabrication

- 16.3.1 The front hoop (side hoop) must follow the line of the A-pillars to the top of the windshield and be connected by horizontal bars to the top of the main hoop on each side (as close to the roof as possible). Instead of a single front hoop, two side hoops (down tubes) may be used.

Alternatively, a top "halo" hoop following the roof line from the main hoop to the windshield with forward down tubes following the A-pillars to the floor may be used. Regardless of which one of the two approved tubing configurations there shall be a tube connecting the two A-pillar tubes at the top of the windshield

- 16.3.2 All bends must be smooth with no evidence of crimping or wall fracturing. All bars should start as close as possible to the floor of the vehicle and come as close as possible to the sides of the vehicle for maximum competitor protection.
- 16.3.3 In the case of tube frame vehicles, the roll cage structure must be attached to the chassis with suitable webbing or gusseting to distribute loads over as wide an area as possible.
- 16.3.4 In the case of unit body vehicles, it is recommended procedure to attach the four ends of the main hoop tubes into L shaped plates at the junction of the floor and rocker panels rather than just to a plate on the floor. Additionally, it is highly recommended that all cages be tabbed into the basic body structure at least every 60cm. (24") or wherever possible.
- 16.3.5 In the case of vehicles where the rear window or bulkhead restricts the installation of rearward braces, (e.g., Fiat X1/9, Toyota MR2, Honda Del Sol) the main hoop may be braced by either of the following methods:

- 16.3.5.1 To permit the installation of standard rearward braces, the rear window may be substituted with a dimensionally identical replacement of clear acrylic or polycarbonate with slots or holes to permit the passage of the brace. Body panels may similarly be slotted or cut only as much as required to facilitate installation of the roll cage braces.

Short rearward braces, welded to the vertical section of the main hoop, may be attached to the standard production shoulder harness hard points. In this case, an additional diagonal brace, of the same dimensions as the main hoop must be also installed, approximately per figure below.

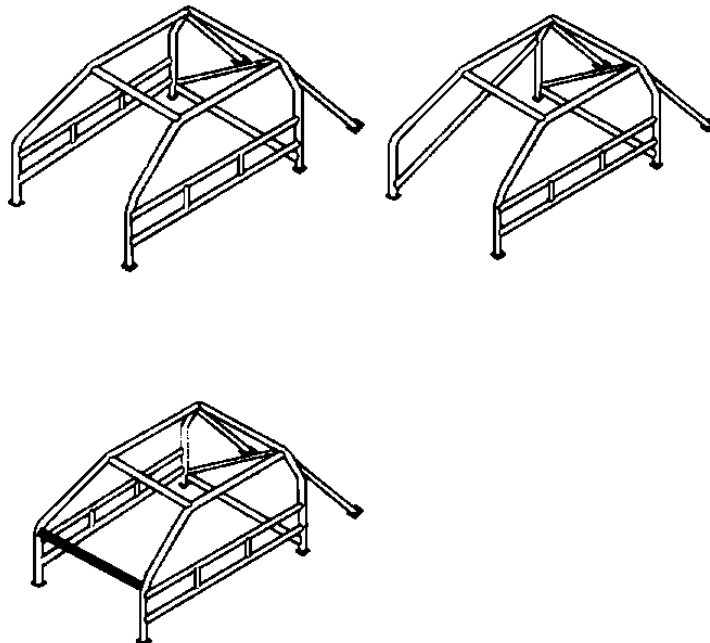

16.4 Bracing

- 16.4.1 In the case of the twin lateral hoop design, the front and rear hoops shall be joined by a piece of equal dimensioned tubing on each side.
- 16.4.2 Rear stays must attach to the rear hoop no lower than 20.32 cm (8") from the top of the hoop and at an angle no steeper than 35 degrees from vertical. These rear stays must be made from a straight piece of tubing and be attached to a suitably stiff or reinforced area.
- 16.4.3 A diagonal brace must be fitted from near the top of the hoop to a position near the opposite corner of the hoop. This brace must be as straight as possible. It is permitted to connect the diagonal from points A-D, B-C, C-F, or D-E of the above diagram. It is recommended that the uppermost point of the diagonal brace be placed behind the driver's seat.
- 16.4.4 Two side protection bars must be attached between the front and rear hoops on both sides of the vehicle. These bars should be attached to the front hoop no higher than 30.48 cm (12") off the floor and on the rear hoop and no higher than 60.96 cm (24") off the floor. NASCAR style multiple anti-intrusion bars are highly recommended. One bar bisecting another to form an "X" is permitted.
- 16.4.5 The removal of inner door reinforcements is authorized in order to facilitate the fitment of the required anti-intrusion bars.
- 16.4.6 A bar joining the two outer members of the front hoop near steering column level is required.
 - 16.4.6.1 It is required that there be two braces (one on either side of the car) extending forward from the front hoop to protect the driver's legs. This bracing should extend to the bulkhead in front of the driver's feet; but, in any case, it shall be integrated into the frame or chassis to provide substantial support for the front hoop.

16.5 Mounting Plates

- 16.5.1 The four lower hoop tubes must be connected to plates welded or bolted to the frame or floor of the vehicle.
- 16.5.2 On unit body vehicles, all plates shall be at least 129 square cm (20 square") in area. The minimum thickness of these plates shall be 0.20 cm (.080") in the case of weld on plates and .1875 for bolt on types. Bolt on types shall have a minimum of three 0.952 cm (.375") grade 5 bolts fastening each plate and must have a backup plate of equal size and thickness on the other side of the floor with the bolts passing through both plates and the floor.
- 16.5.3 Vehicles with frame type construction must use plates of at least 51.6 square cm (8 square") area and .1875 thickness regardless of whether they are bolted or welded.

16.6 Welding

- 16.6.1 It is essential that all welding be of the highest possible quality. Slag welds, poor arc and gas welds are NOT acceptable. It is highly recommended that only certified people carry out arc welding on roll cages. TIG or MIG are the preferred welding processes. Cages with unacceptable welding will not be approved.

16.7 Gusseting

- 16.7.1 It is important that loads be distributed over as wide an area as possible especially in the case of cages on space frame type vehicles. Gussets or tie-in tubes may be used at main tube junctions of the roll cage members. Gussets must be used when it is not possible to weld all around a tube because of body interference. Gusset thickness should be at least the same as the tubing wall thickness they are attached to.

16.8 Removable Type Cages

- 16.8.1 Removable roll cages may be fitted to vehicles only if their construction and design allow them to meet the strength requirements of the designs above.
- 16.8.2 Where tubes join, a double shear type mating tab may be used. Where such a tab is used, the tube joining this tab shall have a small piece of tubing welded perpendicular to its length for the bolt to pass through to prevent crushing of the main tube. Tabs shall be at least 3.49 cm (1.375") wide and 0.476 cm (.1875") thick and must be welded to one of the main tubes. When single bolts are used to fasten tubes, they must be of at least 1.11 cm (.4375") diameter and grade 8 material.
- 16.8.3 Sliding tube type junctions may also be used if they meet the following criteria:
- 16.8.3.1 Wall thickness of the joining tube shall be a minimum of 0.30 cm (.120").
- 16.8.3.2 Length of this tube shall be a minimum of 7.62 cm (3") on either side of the splice.
- 16.8.4 Attachment shall be made using two bolts on each side of the splice 90 degrees to each other passing straight through the tubing. Grade 5 bolts of at least 9.52 cm (.375") diameter shall be used here. Splicing tubes may be slid either inside the main tubing or over the outside.
- 16.8.5 Alternate joint designs may be approved at the discretion of the Chief Scrutineer.
- 16.8.6 Basic design and fabrication of removable type cages must conform to the specifications for non-removable type cages.

16.9 Alternate Designs

- 16.9.1 Rollover structures fully complying with FIA or other sanctioning body regulations may be accepted as complying with these regulations by the Chief Scrutineer on a case-by-case basis.
- 16.9.2 Alternate cage designs may be approved by the Chief Scrutineer provided the competitor can produce stress analysis data from a certified engineer stating that the roll over structure is capable of withstanding the following loads applied simultaneously to that structure:
- 1.5 G lateral
 - 5.5 G fore/aft
 - 7.5 G vertical
- 16.9.3 Calculations shall assume the all up race weight of the vehicle with competitor on board and a full fuel load.

16.10 Additional Roll Cage Diagrams (Formula or Open Car)

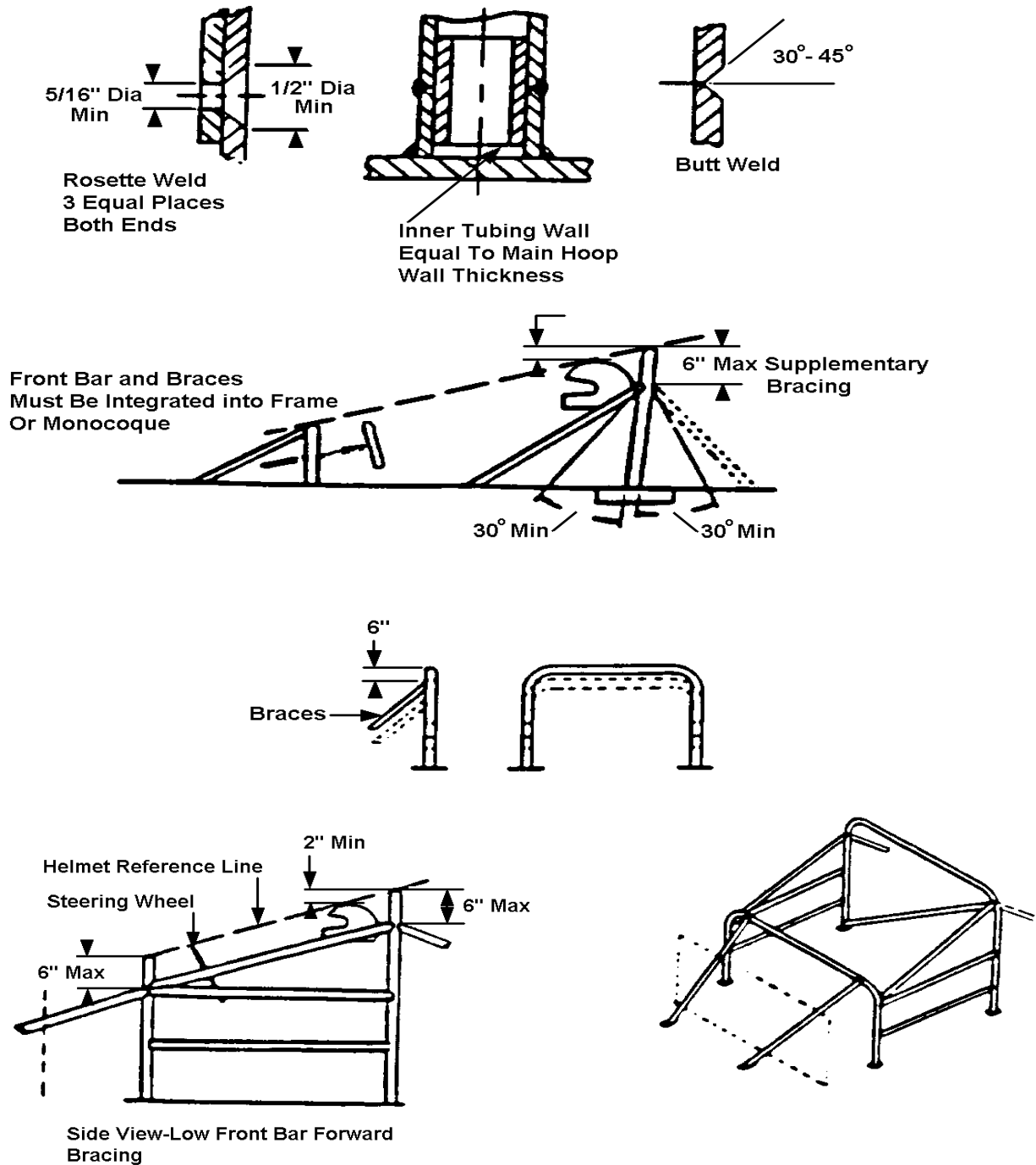

17 Roll Bar Specifications

17.1 General

- 17.1.1 Where permitted or specified by the regulations of a series or event, roll bars meeting the following specifications shall be fitted to all cars
- 17.1.2 It is highly recommended that roll cages meeting the specifications outlined in Section 16 be fitted to all cars competing in events where roll over protection is required.
- 17.1.3 The top of the roll bar shall be at least 5.08 cm (2") above the top of the competitors' helmet or as close to the roof as possible. The top of the roll bar shall be no more than 25.4 cm (10") behind the competitor's helmet when the competitor is in the normal driving position.
- 17.1.4 It is highly recommended that any part of the roll bar or of the car's structure which may be struck by the competitor's helmet in a serious impact, be covered with a flame-retardant energy absorbing material. Padding meeting SFI spec 45.1 is highly recommended.

17.2 Construction Materials

- 17.2.1 The main hoop and primary bracing should be constructed from round, mild steel, ERW or DOM type tubing. Chrome-moly tubing such as 4130 may be used but is not recommended. It is recommended, and may become a requirement, that only DOM tubing be used in the construction of roll cages.
- 17.2.2 Aluminum and composite materials are prohibited construction materials for roll bar structures.
- 17.2.3 All bars must have a 0.476 cm (.1875") diameter inspection hole drilled in each main hoop.
- 17.2.4 Recommended tubing sizes are as follows with vehicle weights including competitor:

Under 1500 lbs.	3.81 cm X 0.30 cm (1.50" X .120")
Under 2500 lbs.	4.45 cm X 0.30 cm (1.75" X .120")
Over 2500 lbs.	5.72 cm X 0.30 cm (2.250" X .120")

17.3 Fabrication

- 17.3.1 One contiguous piece of tubing must be used for the main hoop.
- 17.3.2 All bends must be smooth with no evidence of crimping or wall fracturing. All bars should start as close as possible to the floor of the vehicle and come as close as possible to the sides of the vehicle for maximum competitor protection.
- 17.3.3 In the case of tube frame vehicles, the roll cage structure must be attached to the chassis with suitable webbing or gusseting to distribute loads over as wide an area as possible.
- 17.3.4 In the case of unit body vehicles, it is recommended procedure to attach the ends of the main hoop tubes into L shaped plates at the junction of the floor and rocker panels rather than just to a plate on the floor. Additionally, it is highly recommended that all bars be tabbed into the basic body structure at least every 60.96 cm (24") or wherever possible.
- 17.3.5 Gussets or tie-in tubes may be used at main tube junctions of the roll bar members. Gussets must be used when it is not possible to weld all around a tube because of body interference. Gusset thickness should be at least the same as the tubing wall thickness they are attached to.

17.4 Bracing

- 17.4.1 Rear stays must attach to the hoop no lower than 20.32 cm (8") from the top of the hoop and at an angle no steeper than 35 degrees from vertical. These rear stays must be made from a straight piece of tubing and be attached to a suitably stiff or reinforced area. In cases where rearward braces are impractical, forward braces are permitted.
- 17.4.2 In order to minimize the distortion of the roll bar in the event of impact on one corner, a diagonal brace is required. Permissible means of fitting this brace are as outlined in FIA regulations. This brace must be a straight as possible.
- 17.4.3 Where a "six point roll bar" is specified by the regulations for a series of event, front stays must attach to the hoop no lower than 20.32 cm (8") from the top of the hoop and at an angle no steeper than 35 degrees from vertical. These front stays must be made from a straight piece of tubing and be attached to a suitably stiff or reinforced area.
- 17.4.4 Where a "five point roll bar" is specified by the regulations for a series of event, a single front stay must attach to the hoop on the driver's side of the vehicle centerline at an angle no steeper than 35 degrees from the vertical. This brace must be made from a straight piece of tubing, extend forward to the diagonally opposite side of the car and be attached to a suitably stiff or reinforced area.

17.5 Removable Bracing

- 17.5.1 Removable bracing may be fitted to vehicles only if their construction and design allow them to meet the strength requirements of the designs above.
- 17.5.2 Where tubes join, a double shear type mating tab may be used. Where such a tab is used, the tube joining this tab shall have a small piece of tubing welded perpendicular to its length for the bolt to pass through to prevent crushing of the main tube. Tabs shall be at least 3.49 cm (1.375") wide and 0.476 cm (.1875") thick and must be welded to one of the main tubes. When single bolts are used to fasten tubes, they must be of at least 1.11 cm (.4375") diameter and grade 8 material.
- 17.5.3 Sliding tube type junctions may also be used if they meet the following criteria:
 - 17.5.3.1 Wall thickness of the joining tube shall be a minimum of 0.30 cm (.120").
 - 17.5.3.2 Length of this tube shall be a minimum of 7.62 cm (3") on either side of the splice.
- 17.5.4 Attachment shall be made using two bolts on each side of the splice 90 degrees to each other passing straight through the tubing. Grade 5 bolts of at least 9.52 cm (.375") diameter shall be used here. Splicing tubes may be slid either inside the main tubing or over the outside.
- 17.5.5 Alternate joint designs may be approved at the discretion of the Chief Scrutineer.
- 17.5.6 Basic design and fabrication of removable braces must conform to the specifications for non-removable designs.

17.6 Mounting Plates

- 17.6.1 The lower hoop tubes must be connected to plates welded or bolted to the frame or floor of the vehicle.
- 17.6.2 On unit body vehicles, all plates shall be at least 129 square cm (20 square") in area. The minimum thickness of these plates shall be 0.20 cm (.080") in the case of weld on plates and .1875 for bolt on types. Bolt on types shall have a minimum of three 0.952 cm (.375") grade 5 bolts fastening each plate and must have a backup plate of equal size and thickness on the other side of the floor with the bolts passing through both plates and the floor.
- 17.6.3 Vehicles with frame type construction must use plates of at least 51.6 square cm (8 square") area and .1875 thickness regardless of whether they are bolted or welded.

17.7 Welding

- 17.7.1 It is essential that all welding be of the highest possible quality. Slag welds, poor arc and gas welds are NOT acceptable. It is highly recommended that only certified people carry out arc welding on roll bars. TIG or MIG are the preferred welding processes. Structures with unacceptable welding will not be approved

17.8 Alternate Designs

- 17.8.1 Alternate cage designs may be approved by the Chief Scrutineer provided the competitor can produce stress analysis data from a certified engineer stating that the roll over structure is capable of withstanding the following loads applied simultaneously to that structure:
- 1.5 G lateral
 - 5.5 G fore/aft
 - 7.5 G vertical
- 17.8.2 Calculations shall assume the all up race weight of the vehicle with competitor on board and a full fuel load.

18 Competitor Safety Equipment

18.1 Minimum Standards

18.1.1 Unless specified otherwise in series, event, class or discipline regulations, these standards constitute the minimum acceptable standard of safety precaution. Individual class preparation rules may increase applicable safety requirements.

18.2 General

18.2.1 Drivers must wear the following equipment during all on-course sessions:

18.2.1.1 A safety helmet which meets one of the following FIA approved standards:

18.2.1.1.1 BS 6658-85 TYPE A/FR with all amendments (Great Britain)

18.2.1.1.2 Snell Foundation SA2010, SAH2010 and SA2015

18.2.1.1.3 SFI, Spec 31.1A and 31.2A (USA) (Note: suffix must include "A")

18.2.1.1.4 FIA standards 8860-2010, 8860-2018, 8858-2002, 8858-2010 or 8859-2015

18.2.1.1.5 Or any helmet listed in current FIA Technical List 25 or FIA Technical List 49

18.2.1.2 Drivers must wear a single-piece driving-suit consisting of two layers of an approved fire-resistant material. Suits bearing a label certifying compliance with SFI standard 3.2.A/3 or better, or the FIA 1986 standard are deemed to comply with this requirement, regardless of material or number of layers.

18.2.1.3 Fire resistant underwear of an approved material must be worn except with suits meeting SFI standard 3.2.A/5 or better, or the FIA standard 8856/2018 or 8856/2000.

18.2.1.4 Socks made of fire-resistant material are mandatory. Shoes and gloves made of leather or any approved fire-resistant material containing no holes are mandatory. Shoes may have synthetic rubber soles. Gloves and shoes must have a layer of fire-resistant material next to the skin.

18.2.1.5 A balaclava made of fire-resistant material must be worn and must cover the neck and head except where required for proper vision and respiration.

18.2.1.6 In the absence of a separate standard, the above driving suit accessories must comply with the SFI standard 3.3, FIA standard 8856/2018 or 8856/2000.

18.2.1.7 Drivers shall wear safety glasses, goggles or a helmet shield (in a lowered position) at all times when the car is on course.

18.2.1.8 Cars shall be equipped with, and the drivers shall utilize, seat belts and shoulder harness meeting the specifications of these regulations.

18.3 Helmets

- 18.3.1 Helmets must be in good condition. Helmets that have deep scratches, gouges, or cracks will not be permitted for use in on-track sessions. It is highly recommended that helmets be kept out of direct sunlight to prevent UV radiation damage.
- 18.3.2 Full face helmets and shields must be worn by drivers of open cockpit cars and are strongly recommended for drivers of closed cars. Drivers of closed cars are cautioned: When choosing a helmet, they should consider the ability of emergency medical personnel to access the driver's mouth and nose in potentially confined spaces without removing the driver from the car.
- 18.3.3 The modification of helmets for the fitment of head and neck restraint systems is authorized. It is highly recommended that such modifications be performed only by a qualified installer.

18.4 Head restraints

- 18.4.1 The use of a Frontal Head Restraint Device complying with FIA standards 8858-2002 or 8858-2010 or SFI Specification 38.1 is mandatory for all Race, Vintage, Time Attack-Passing, and Hill Climb drivers.
- 18.4.2 The use of a Frontal Head Restraint Device complying with FIA standards 8858-2002 or 8858-2010 or SFI Specification 38.1 is recommended for Autoslalom, Ice Race and Sprint drivers in cars equipped with 5 or 6 point harnesses.

19 Driver Restraint System

19.1 Minimum Standard

- 19.1.1 Unless specified otherwise in series, event or discipline regulations, all drivers in CACC events must utilize either a five (5) or six (6) point restraint harness meeting FIA standard No. 8853/98, 8854/98, 8853-2016 or SFI standard 16.1 or 16.5 (either Type 1 or Type 1A) at all times during practice, qualifying and the race. The restraint system installation is subject to approval of the Chief Scrutineer.
- 19.1.2 A five (5) point or six (6) point system is required for use in cars where the driver is seated in an upright position and consists of lap belts, two (2) approximately 3 inch shoulder harnesses; 2 inch shoulder harnesses may be used only if an approved Frontal Head Restraint is worn by the driver and one (1) or two (2) antisubmarine straps
- 19.1.3 A six (6) point system is required for use in cars where the driver is seated in a semi- reclining position and consists of a lap belt, two (2) approximately 3 inch shoulder harnesses; 2 inch shoulder harnesses may be used only if an approved Frontal Head Restraint is worn by the driver and two (2) anti-submarine straps and is recommended for all cars.

19.2 Construction

- 19.2.1 The buckles must be of metal-to-metal quick release type except in the case of leg straps of the six (6) point system, where they may be attached to the seat belt or shoulder harness straps.
- 19.2.2 The shoulder harness shall be the over-the-shoulder type. There must be a single release common to the seat belt and shoulder harness.

19.3 Shoulder Harness

- 19.3.1 The shoulder harness shall be mounted behind the driver and above a line drawn downward from the shoulder point to an angle of forty (40) degrees with the horizontal.
- 19.3.2 In cases where the driver is in a semi-reclining position, the shoulder harness shall be attached so that the angle between a line drawn through the driver's spine and the shoulder harness is forty-five (45) degrees or greater.
- 19.3.3 Only separate shoulder straps are permitted. "H" type configuration is allowed. "Y" type shoulder straps are not allowed.
- 19.3.4 It must be noted that the restraint system meeting FIA standard No. 8853/98, 8854/98, 8853-2016 or SFI standard 16.1 (either Type 1 or Type 1A) may not be modified in any way. Padding may be added for additional driver comfort.

19.4 Anti-submarine Straps

- 19.4.1 The single anti-submarine strap of the five (5) point system shall be attached to the floor structure of the car similar to the shoulder harness mounting and have a metal-to-metal connection with the single release common to the seat belt and shoulder harness. The anti-submarine strap must be a minimum of 50 mm (2") in width.
- 19.4.2 The double leg straps of the six (6) point system may be attached to the floor as above for the five (5) point system or be attached to the seat belt so that the driver sits on them, passing them up between the legs and attached either to the single release common to the seat belt and shoulder harness or attaching to the seat belt or shoulder harness straps.

19.4.3 It is also permissible for the leg straps to be secured at a point common to the seat belt attachment to the structure passing under the driver and up between the legs to the seat belt release or shoulder harness straps.

19.4.4 All straps must be free to run through intermediate loops or clamps/buckles.

19.5 Arm Restraints

19.5.1 Drivers of open cockpit cars must use SFI or FIA approved arm restraints. Restraints shall be worn in such a manner as to prevent elbows from leaving the confines of the cockpit area.

19.6 Mounting

19.6.1 The minimum acceptable bolts used in the mounting of all belts and harnesses are SAE grade 5. Where possible, seat belts, shoulder harness and anti-submarine straps should be mounted to the roll structure or frame of the car. All harness mounting bolts must be of 10 mm (0.375") shank diameter, minimum.

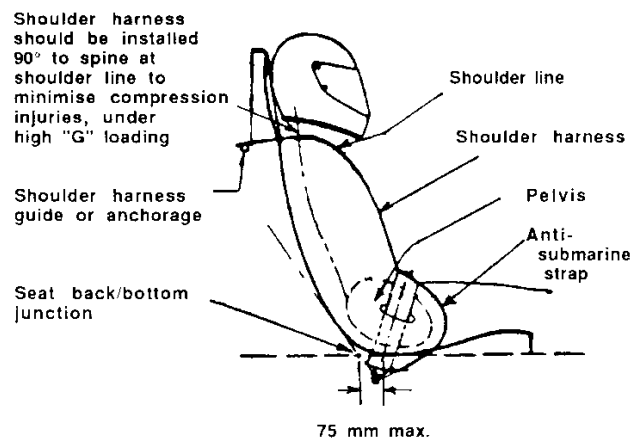

75 mm max. to centreline of lap belt at seat back/seat bottom junction. Lap belt should continue in straight line to anchorage.

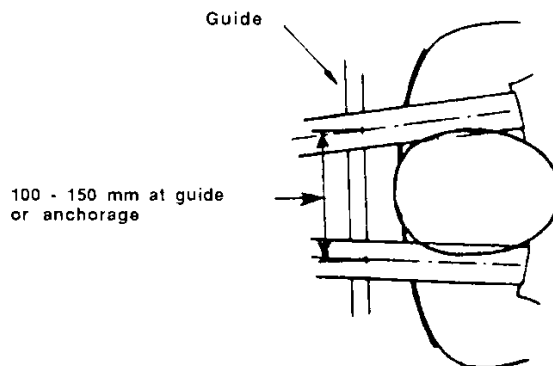

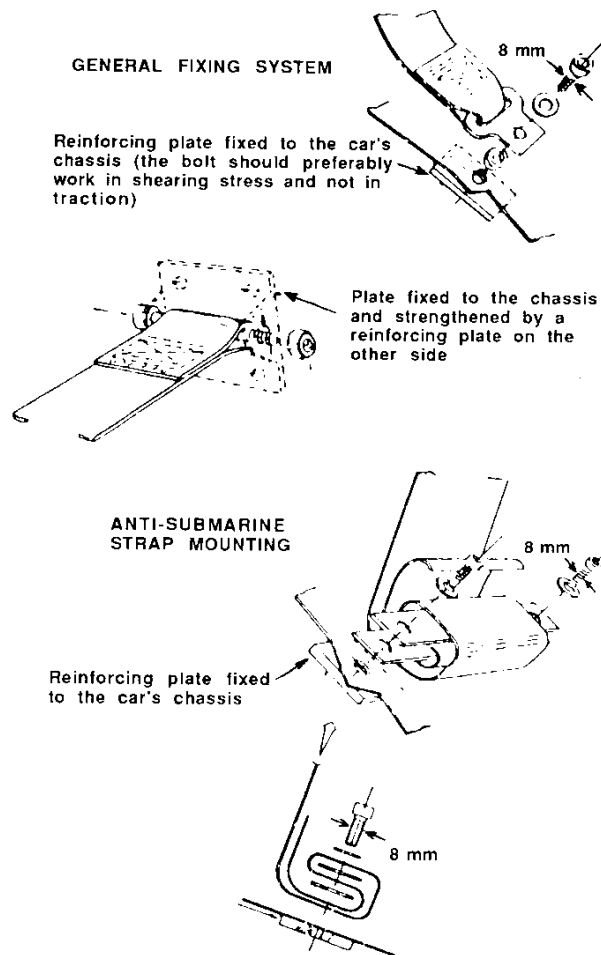

- 19.6.2 Where it is not possible to mount belts and straps directly to the roll structure or frame of the car and they must be attached to a structural panel, for example, the panel must be suitably reinforced in a workmanlike manner to prevent distortion under load. Steel reinforcing plates of adequately large area and thickness must be installed to prevent the belt attachment from pulling through the panel under load.
- 19.6.3 Bolting directly to the floor panels, etc. without adequate reinforcement is not acceptable.
- 19.6.4 It is required that clip-in buckles on the driver restraint system must be secured with a cotter pin or locking wire to prevent accidental release.

19.7 Life Span

- 19.7.1 Belts must bear a legible date stamp from the manufacturer.
- 19.7.2 Driver restraint systems meeting SFI specifications expire after two years from date of manufacture. These belts shall not be used after the expiration date of the SFI certification. (i.e., a belt manufactured in May 2017 shall not be used after May 31, 2019). Driver restraint systems meeting FIA specifications must have all belts labelled with their date of expiration, and these belts will expire on the last day of the year indicated on their labels.

20 Vehicle Safety Requirements

20.1 General

- 20.1.1 Unless specified otherwise in series, event or discipline regulations, these standards constitute the minimum acceptable standard. Individual class preparation rules may increase applicable requirements.

20.2 Brakes

- 20.2.1 All racing vehicles must use a dual-circuit hydraulic braking system.

20.3 Engine Catch Tanks

- 20.3.1 In order to prevent fluid spillage, all fluid reservoir and sump vent tubes must be routed to a suitable container of one (1) litre minimum capacity for one (1) litre vehicles and two (2) litres minimum capacity for over two (2) litre vehicles. Any catch tanks shall be translucent or be fitted with sight tubes to facilitate easy checking of their contents.

20.4 Electrical

- 20.4.1 Any electric starter may be used. The main starter cable terminal must be securely insulated.
- 20.4.2 An external boosting system to assist the vehicle's electrical system may be installed, provided that it cannot be accidentally shorted.
- 20.4.3 Alternators may be removed or substituted.
- 20.4.4 All cars, except Vintage shall be equipped with a master switch easily accessible from outside the car. The master switch shall be installed directly in either battery cable and shall cut all electrical circuits but not an on-board fire system. All terminals of the master switch shall be insulated to prevent shorting out. It shall be clearly marked by the international marking of a spark in a blue triangle and mounted in a standard location. Off position shall be clearly indicated at the master switch location. The standard locations shall be as follows:
- 20.4.4.1 Formula and Sports Racing Cars – In proximity to the right-hand member of the roll bar, but in a location so that it cannot be operated accidentally. It can be mounted on a bracket welded to the inside of the upright member or mounted so that the operating lever or knob is outside of the body panel immediately in-board of the upright member.
- 20.4.4.2 Closed Sports Racing Cars, Improved Production Cars, GT and GTS cars – In front of the windshield on either the cowl or on top of the fender, but close enough to the windshield to be accessible if the car is overturned. Alternatively, it may be mounted below the center of the rear window or on a bracket welded, clamped or bolted to the roll cage or dash, easily accessible through the open window. (Drilling of holes in roll cage to attach the bracket is prohibited.)
- 20.4.4.3 Open Production, GT, and Improved Touring Cars – May exercise a choice among the above locations.

20.5 Window Glass/Nets

- 20.5.1 All windows must be of laminated windshield safety glass, tempered safety glass, or three (3) mm minimum thickness polycarbonate materials, as permitted in the individual class preparation regulations. Acrylic plastic glass is prohibited. For GT class cars, windshields conforming to current SCCA GT regulations are permitted
- 20.5.2 Sedans must have the driver's door window fully open or removed during all on-track sessions. A strap-type window net must be fitted such that the driver's arm(s) cannot extend outside the vehicle unintentionally. Mesh type window nets complying with SFI standard 27.1 are permitted. Window nets must be fitted to the main structure of the car, or if fitted to the door, the door must be pinned to prevent accidental opening in the event of a collision or rollover. All window nets must be fitted to the vehicle using a quick release mechanism acceptable to the Chief Scrutineer.
- 20.5.2.1 Window nets meeting SFI specifications expire after two years from date of manufacture. These nets shall not be used after the expiration date of the SFI certification. (i.e., a net manufactured in May 2017 shall not be used after May 31, 2019). Window nets meeting FIA specifications labelled by the manufacturer with their date of expiration, will expire on the last day of the year indicated on the label.
- 20.5.3 Where not otherwise specified by applicable class regulations, the passenger door window may remain in place; however, the window (or door/window combination) must be operable from outside the vehicle without the use of tools in order to permit access to the driver/passenger compartment.

20.6 Onboard Fire Suppression Systems

This rule pertains to on board fire suppression systems where they are required by class regulations or are installed by choice.

On-board fire systems may use Halon 1301 or 1211, with a five pound minimum capacity (by weight). Alternatively, on-board fire systems may use AFFF or equivalent surfactant foam material, 2.25-liter minimum capacity (by volume). All AFFF fire system bottles shall incorporate a functional pressure gauge and shall be marked with the manufacturer's recommended "filled weight." CO2 cartridge propellant fire extinguishing systems are permitted provided that the seal of the manufacturer specified CO2 cartridge is not punctured and the fire bottle is equal to the weight specified by the system manufacturer.

Cars shall meet the following regardless of registration date:

- 20.6.1 The fire system cylinder shall be securely mounted in such a manner that it can be checked during a technical inspection and may be removed for weighing periodically for compliance to full weight shown on the cylinder. (Weight is without valve assembly.) Manual or automatic release is allowed. The release mechanism shall be within reach of the driver when belted in the car.
- 20.6.2 All on-board fire systems shall be identified with a circle "E" decal.
- 20.6.2.1 In GT, GTS and Improved Production cars, two circle "E" decals may be required – one at the release location and the second on the outside bodywork in line with or as near to the release location as possible.
- 20.6.2.2 In Formula and Sports Racing cars, a circle "E" decal shall be located on the outside bodywork as near to the release location as possible.

- 20.6.3 There shall be a minimum of two nozzle locations – one in the driver's compartment and one in either the engine area or the fuel cell area. The nozzles shall be suitable for the type of extinguishing agent used.
- 20.6.4 All AFFF fire system bottles shall incorporate a functional pressure gauge. This does not apply to non-pressurized AFFF systems with CO2 propellant.
- 20.6.5 The firing safety pin(s) shall be removed from all on-board fire systems prior to going on track. It is recommended that a warning tag be attached to the safety pin to remind the driver to remove the safety pin before entering the racing surface.
- 20.6.6 All fire systems shall be serviced according to manufacturer's specifications.

20.7 Seats

- 20.7.1 A one-piece racing seat must be fitted in place of the standard driver's seat. The passenger seat may be removed or replaced with a racing seat. Improved Production classes may use original equipment seats, provided that an adequate headrest (as defined below) is fitted to the rollover structure.
- 20.7.2 All seats must provide a headrest; alternately, a padded head rest may be affixed to the roll cage. The head restraint must have a minimum area of 235 square cm (36 square") and be capable of absorbing two hundred (200) pounds force in a horizontal direction. The headrest must be within five (5) centimeters (2 inches) of the driver's helmet in a normal seated position.

20.8 Seat Mounting

- 20.8.1 It is required for GT category cars and recommended for IP category cars that the driver's seat be firmly mounted to the structure of the car. This is also mandatory for IP car that have had the original equipment driver's seat replaced with another. In cars where the seat is upright (most common in GT and IP/IT cars) the back of the seat shall be firmly attached to the main roll hoop, or its cross bracing, so as to provide aft and lateral support. Bulkheads, firewalls, rear decks, or similar structures of suitable strength may be used as a substitute for the main roll hoop or cross bracing to provide the required seat back support.
- 20.8.2 Where a car is fitted with a seat complying with FIA standard 8855/2021 or 8855/1999 the seat must be mounted according to the manufacturer's instructions. If these instructions omit the seatback mountings, the entrant should present a copy of those instructions at scrutineering.

20.9 Fuel System

- 20.9.1 Where their use is required or permitted by class regulations, fuel cells must be constructed and certified in accordance with either FIA Specifications FT3 1999, FT3.5 or FT5, or SFI standard 28.1 and must be mounted to a substantial structure in accordance with the manufacturer's instructions. Attaching the fuel cell to sheet metal only is not considered to be adequate.
- 20.9.2 Where their use is required or permitted by class regulations, it is highly recommended that fuel cells be serviced according to the manufacturer's recommendations or on the following basis:
- 20.9.2.1 External bladders (not the metal container) should be replaced five (5) years after their date of manufacture. Alternatively, the bladder may be returned to its manufacturer for re-inspection, and with their approval, it may be returned to service for a maximum of two (2) additional years.
- 20.9.2.2 Where used, the internal baffling foam should be replaced every two (2) years.

- 20.9.3 Fuel tanks must be isolated from the driver passenger compartment by a metal bulkhead sufficient to prevent the passage of flame and liquid.

20.10 Lines and Hoses

- 20.10.1 Lines or hoses carrying, or potentially carrying, oil, fuel or other flammable liquid, and passing through or into the driver/passenger compartment shall be constructed of steel tubing or be covered by a supplemental metal covering.

20.11 Tow Hooks

- 20.11.1 All cars without an exposed roll bar shall have a towing eye or strap, front and rear that does not dangerously protrude from the bodywork when the car is racing, to be used for flat-towing or hauling the vehicle. A removable towing eye carried inside the car is not acceptable, except in formula cars and sports racers. These towing eyes or straps shall be easily accessible without removal or manipulation of bodywork or other panels. Towing eye minimum ID two (2) inches. A fold-down or strap type tow eye is preferred.
- 20.11.2 The required tow eyes must be strong enough to tow the car from a hazard such as a gravel trap. Front tow eye may be mounted in the driver / passenger side window openings, or any location forward of the windshield. If mounted in the driver/passenger side window openings, it must be attached to the forward roll cage down tube as close to the base of the windshield as possible. If the front tow eye is located in the side window openings there shall be one on each side of the car. Rear tow eyes must be accessible rearward of the rear axle centerline.

20.12 In Car Cameras/Radios

- 20.12.1 In car camera or video recording equipment is permitted provided the installation is approved by the scrutineers and subject to the provision that any photographic film or video recording made during the track session may be impounded by the Steward.
- 20.12.2 Excepting the receiving of standard broadcast radio signals, it is prohibited that telemetric signals be transmitted from or received by any car during any official on track session unless prior express written consent is received from the Steward in consultation with the clerk of the course. Regulations may permit two way voice only radio communications. Live Broadcasting is specifically not permitted.
- 20.12.3 Two way voice communication is permitted only between the driver and crew. For further clarity, in car voice communication between drivers is not permitted.
- 20.12.4 Any radio communications used must not interfere with race control or any other race track emergency network. A team representative must inform the clerk of the course of the team's radio frequency.

21 Racing Numbers and Class Designation

21.1 Competition Numbers

- 21.1.1 Competition numbers shall be applied only as follows or unless the discipline regulations state otherwise:
- 21.1.1.1 The numbers must be at least ten (10) inches high on production-based cars and eight (8) inches high on open wheel cars. The minimum width of stroke of all numbers is two (2) inches.
 - 21.1.1.2 The numbers must be in a solid colour, on a solid background of a significantly contrasting colour. Black on white is preferred and recommended.
 - 21.1.1.3 One (1) number must be on the front hood of production-based cars and on the nose of open wheel cars.
 - 21.1.1.4 One (1) number must be on each side of the car positioned on the body above an imaginary line running through the center line of the wheels. Open wheel cars may vary this location, however, side numbers shall in no way be partially or completely obscured by the vehicle's wheels.
 - 21.1.1.5 On production-based cars, a competition number, one half the size of the normal number, must be placed on the rear of the car on a vertical surface and must be clearly visible and legible.
 - 21.1.1.6 Karts – To be added
- 21.1.2 Metallic or other highly reflective numbers are not permitted.
- 21.1.3 Cars not meeting the specification of this regulation, in the opinion of the steward, during any scheduled track session will be black-flagged and not allowed to re-enter the track until the numbers are in compliance.

21.2 Class Designation

- 21.2.1 Class designation shall be applied as follows:
- 21.2.1.1 The class designation shall be at least one half the size of the numbers.
 - 21.2.1.2 The class designation shall be placed close to the numbers on the sides of the car.

21.3 Competition Vehicles on Public Roads

- 21.3.1 Competition numbers should be removed from track-driven vehicles when operated on public roadways.

22 EV (Electric Vehicle) Electrical Safety

Electric Vehicles may compete, as allowed by class rules, as long as they meet the requirements of Section 22. Production Electric Vehicles that meet the CACC Race Regulations for Improved Production vehicles are considered to have met the requirements of Section 22.2.

22.1 General

- 22.1.1 **Master Switch.** There must be a clearly marked switch, accessible by both the driver and safety workers, which will de-energize both the vehicle high and low voltage systems. This switch shall meet the requirements of Section 20.4.4. For Production Vehicles, this switch must only interrupt the low voltage battery feed to accomplish the shutdown.
- 22.1.2 **High Voltage System Energized.** Whenever the High Voltage system is energized, one or more flashing amber lights must be activated. These lights must be visible in daylight and must be placed so that they are visible from all sides of the vehicle.
- 22.1.3 **Vehicle Powertrain Identifier.** Electric Vehicles must be marked on both sides of the vehicle with the orange electrified diamond per ISO 17840-4. One symbol must be placed on each side of the vehicle in front of or behind vehicle number and must be a minimum of 6" tall.

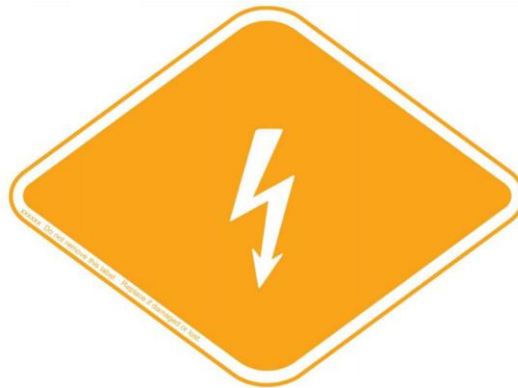

- 22.1.4 **Fire Suppression.** A Fire suppression system meeting CACC regulations for Onboard Fire Suppression Systems must be installed. Nozzles should be directed into the driver's compartment between the battery pack and driver. If the Battery Pack is of a custom design, additional nozzles should be directed into the battery pack enclosure.
- 22.1.5 **Charging:**
- 22.1.5.1 Electric vehicles may not be charged in the pre-grid or hot pits.
- 22.1.5.2 Onboard chargers must utilize a commercially available Electric Vehicle Supply Equipment (EVSE) to charge from a 120/240VAC electrical supply.
- 22.1.5.3 Off-vehicle charging systems may be utilized as long as they are galvanically isolated between the AC and DC outputs and the charger enclosure is connected to Earth Ground of the AC input and Vehicle Chassis Ground. A crew member must continually monitor the charging operation.

22.2 Modified Electric Vehicles

Other than Production Electric Vehicles that meet CACC Race Regulations, all other Electric Vehicles must meet the requirements of Section 22.2.

- 22.2.1 **Fuse.** An appropriate sized fuse must be installed on the positive lead of the main battery pack before the Main Contactor and Service Disconnect.
- 22.2.2 **Contactors.** Contactors must be installed on both the positive and negative leads of the battery pack to allow the control system, or Master Switch, to completely disconnect the battery.
- 22.2.3 **Service Disconnect.** In addition to the Master Switch, there must be a Service Disconnect which mechanically breaks the positive high voltage lead from the battery. The Service Disconnect must be clearly marked and must be accessible to the driver, crew, and safety workers.
- 22.2.4 **High Voltage Wiring & Contacts.** Visible high voltage wiring must be orange in color. No HV potential shall be exposed anywhere on the vehicle under normal operation. Any components with high voltage contacts, or devices inside, shall have ISO 7010 Electrical Warning decals attached.

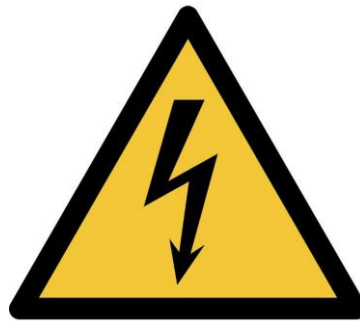

22.2.5 Battery Pack Design & Mounting:

- 22.2.5.1 Custom Battery Packs, or OEM battery packs that have been modified in any way, may only be installed in vehicles with a roll cage. The complete battery pack must be inside the roll structure. Battery packs must utilize commercially available cells/modules. It is prohibited to modify individual cells except for the tab connections to enable connection. Individual cells/modules must be securely fastened together and mounted in a protective enclosure. The enclosure mounting system must be able to contain the battery pack in a vehicle crash, and the cell/module retaining system should prevent shorting of any High Voltage components.
 - 22.2.5.2 The battery pack enclosure should be constructed of aluminum, steel, or other materials which will not melt/combust in the event of a battery fire. Composite sandwich materials are acceptable if at least one of the layers is aluminum or steel.
 - 22.2.5.3 The bottom of the battery pack shall be protected by steel, alloy aluminum, or composite material to prevent penetration damage by foreign objects.
- 22.2.6 **Battery Management System (BMS).** A commercially available BMS must be installed to monitor battery pack operating conditions. As a minimum, it needs to monitor individual cell voltages and the battery pack temperature. The BMS must alert the driver/crew if any cell drops below the minimum cell limit or exceeds the maximum cell limit, or the pack temperature rises above the safe operating temperature specified by the manufacturer of the battery cell. During charging, the BMS must automatically shut-off charging when the battery pack is fully charged.



- 22.2.7 **Voltage Isolation.** The battery pack, and all high voltage components, must be electrically isolated from the chassis ground at all times. A minimum of 500 ohms isolation per volt is required. The Battery Management System, or a separate Isolation Monitor, must alert the driver/crew of any isolation problem during vehicle operation or charging.
- 22.2.8 **Motors and Inverters.** Only commercially available production motors and inverters are permitted. Re-purposed OEM motors and power electronics may be utilized.